



C16-A/BM/CH/CHST/AEI/MNG/
MET/TT/IT/PCT—107

6005

**BOARD DIPLOMA EXAMINATION, (C-16)
OCT/NOV—2017
FIRST YEAR (COMMON) EXAMINATION**

ENGINEERING DRAWING

Time : 3 hours]

[Total Marks : 60

PART—A

5×4=20

Instructions : (1) Answer **all** questions.

(2) Each question carries **five** marks.

(3) Take suitable scale wherever required.

(4) All dimensions are in mm.

1. Print the following in 12 mm size capital single-stroke inclined lettering :

GOVERNMENT OF ANDHRA PRADESH

2. Redraw the following figure to the full scale and dimension it as per uni-directional system :

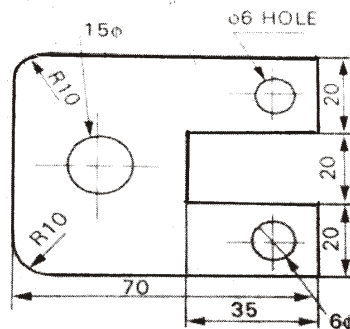

* 3. Draw a pentagon of side 30 mm by regular method.

4. Draw the auxiliary view of the sloping side of the object given below :

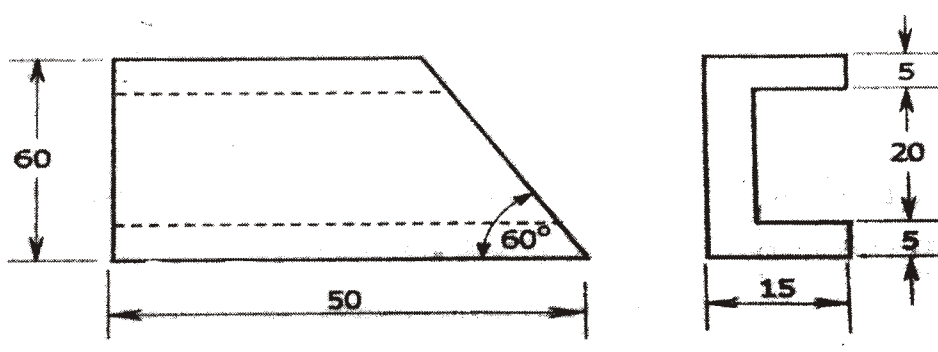

PART—B

10×4=40

Instructions : (1) Answer *any four* questions.

(2) Each question carries **ten** marks.

(3) Take suitable scale wherever required

(4) All dimensions are in mm.

5. Construct an ellipse whose major and minor axes are 100 mm and 80 mm respectively by using concentric circles method.

* 6. A hexagonal pyramid with side of base 30 mm and axis 75 mm long is resting its base on HP and two edges of the base are parallel to VP. It is cut by a section plane parallel to HP and passing through the axis at a point 40 mm from the apex. Draw the projections of the remaining pyramid.

*

7. Draw the front view, top view and side view of the object shown below :

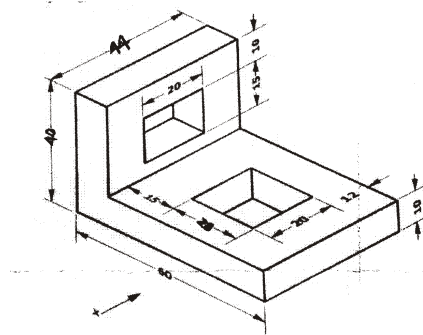

8. A cone 30 mm radius and 70 mm axis is resting on its base on HP. A cutting plane perpendicular to VP and 30 degrees to the HP cuts the cone at mid height of the cone. Draw the front view and sectional top view.
9. Draw an isometric view of an object whose orthographic views are given in the following figure :

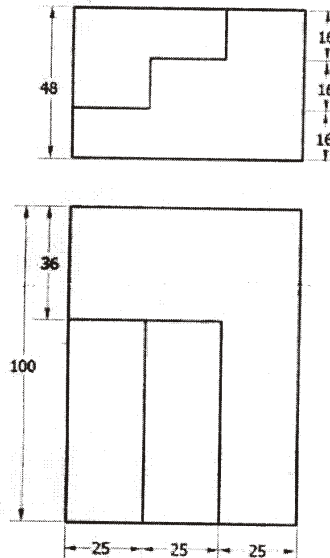

10. A cone of base 50 mm diameter and height 60 mm rests with its base on HP. A section plane perpendicular to VP and inclined at 30 degrees to HP bisects the axis of the cone. Draw the development of the lateral surface of the truncated cone.
