

* 4483 *

C14-M-407

4483

BOARD DIPLOMA EXAMINATION, (C-14)
MARCH/APRIL—2018
DME—FOURTH SEMESTER EXAMINATION
PRODUCTION DRAWING PRACTICE

Time : 3 hours]

[Total Marks : 60

PART—A

5×4=20

- Instructions :** (1) Answer **all** questions.
(2) Each question carries **five** marks.
(3) Draw the following neatly with proportionate dimensions.
(4) Use of production drawing tables is allowed.

1. The dimensions of a shaft and hole are given below

+0.010 +0.020
-0.005 -0.022

Hole 50 Shaft 50

Find (a) hole tolerance. (b) shaft tolerance. (c) minimum allowance.
(d) maximum allowance and (e) type of fit for the assembly.

1+1+1+1+1

2. Draw the comprehensive symbol of surface roughness and indicate all the elements on it. 5

3. Explain the following designations: 1+1+1+2

(a) Fe 410 Cu K

(b) Fe 470W

(c) X10 Cr 18 Ni 9 S3

(d) Hex bolt M20×1.5×7.5NL-IS 1364-S-4.6

4. What are steps to be followed in preparing Blueprints of a Drawing?

PART—B

40

Instruction : (1) Answer *any one* of the following questions.

5. Study the given assembly drawing of the Stuffing Box shown in figure : 20+5+4+5+4+2

- (a) Draw the component drawings.
- (b) Apply suitable tolerances and fits.
- (c) Apply suitable geometrical tolerances to components.
- (d) Prepare the process sheet for Gland.
- (e) Show the surface roughness symbols.
- (f) List out the materials of the components.

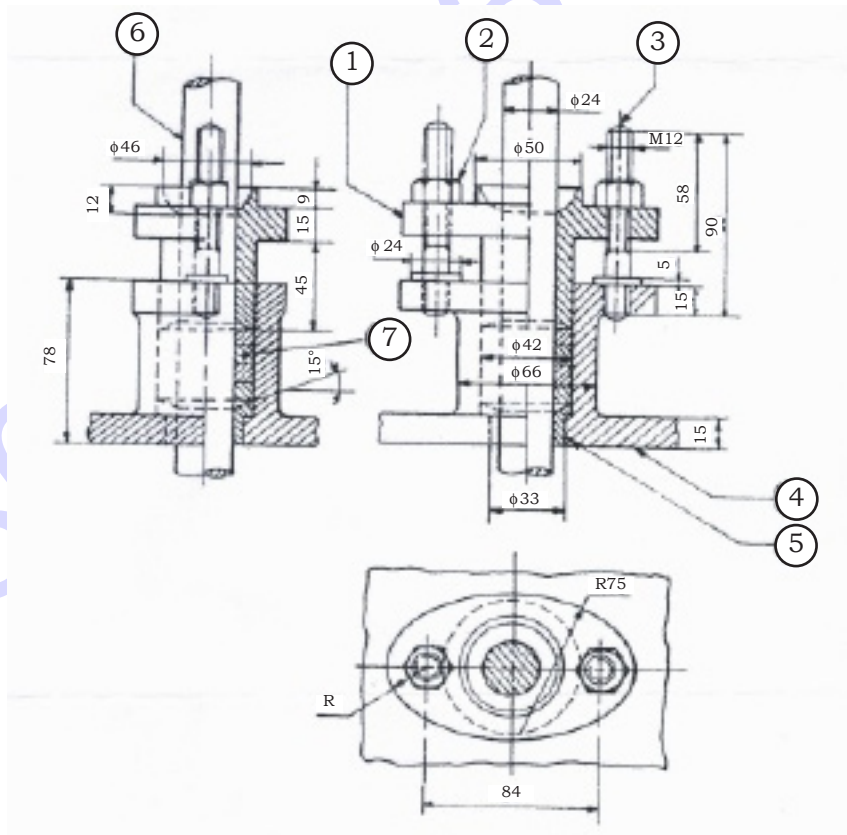

Parts list :

Part No.	Name	Qty
1.	Gland	1
2.	Nut	2
3.	Stud	2
4.	Body	1
5.	Bush	1
6.	Shaft	1
7.	Packing	1

6. Study the given assembly drawing of the Universal Coupling shown in figure : 20+5+4+5+4+2

- (a) Draw the component drawings.
- (b) Apply suitable tolerances and fits.
- (c) Apply suitable geometrical tolerances to components.
- (d) Prepare the process sheet for Gland.
- (e) Show the surface roughness symbols.
- (f) List out the materials of the components.

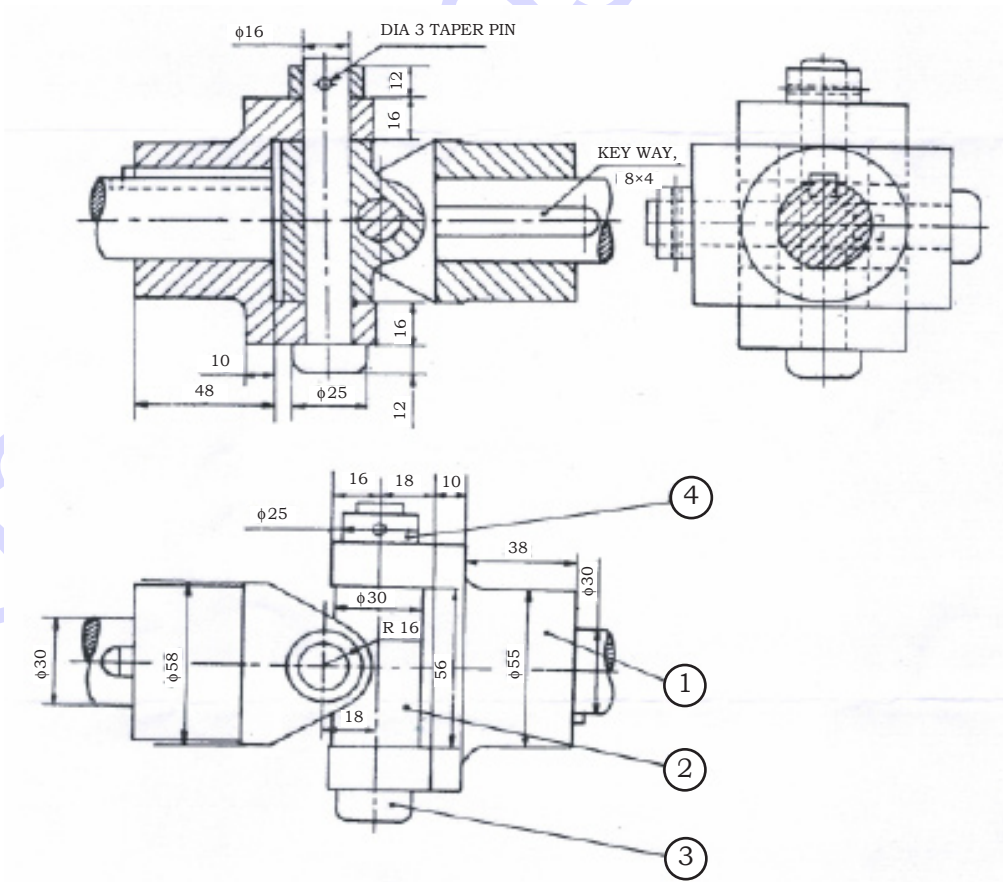

Parts list :

*

Part No.	Name	Qty
1.	Fork	2
2.	Centre block	1
3.	Pin	2
4.	Coller	2

* * *

030 030 030 030

*

*