



* 4 0 5 4 *

C14-M-105

4054

BOARD DIPLOMA EXAMINATION, (C-14)

OCT/NOV—2017

DME—FIRST YEAR EXAMINATION

ENGINEERING MECHANICS

Time : 3 hours]

[Total Marks : 80

PART—A

3×10=30

Instructions : (1) Answer **all** questions.

(2) Each question carries **three** marks.

(3) Answer should be brief and straight to the point and shall and not exceed *five* simple sentences.

1. Define the terms 'couple' and 'moment of couple' with a neat sketch.

2. State the parallelogram law of forces.

3. Define the following terms :

(a) Coefficient of friction

(b) Normal reaction.

4. Define static friction and dynamic friction.

5. A hollow circular section has an external dia of 8 cm and internal diameter of 6 cm. Find its MI about the horizontal axis passing through its centre.

*

6. The piston of the steam engine moves with SHM, the crank rotates at 120 r.p.m. with a stroke of 2 m. Find the velocity and acceleration of the piston when it is at a distance of 0.75 meter from the centre.
7. Define law of conservation of energy.
8. What is a simple machine? List out any three simple machines.
9. The law of the machine is $p = 0.04w$. If VR = 50, what is the MA and efficiency when $W = 200$ N?
10. List three examples of lower and higher pairs.

PART—B

10×5=50

- Instructions :** (1) Answer *any five* questions.
(2) Each question carries **ten** marks.
(3) Answers should be comprehensive and the criterion for valuation is the content but not the length of the answer.

11. The forces acting at a point are given below :
 - (a) 15 N inclined at 30° towards North to East
 - (b) 20 N towards North
 - (c) 25 N towards North-West
 - (d) 30 N inclined at 40° towards South of West. Find the magnitude and direction of resultant of the forces.
12. A body resting on a rough horizontal plane required a pull of 180 N inclined at 30° to the plane just to move it. It was found that a push of 220 N inclined at 30° to the plane just moved the body. Determine the weight of the body and the coefficient of friction.

*

- * **13.** Find the MI of a T-section shown in the figure below about $x-x$ axis passing through the CG of the section :

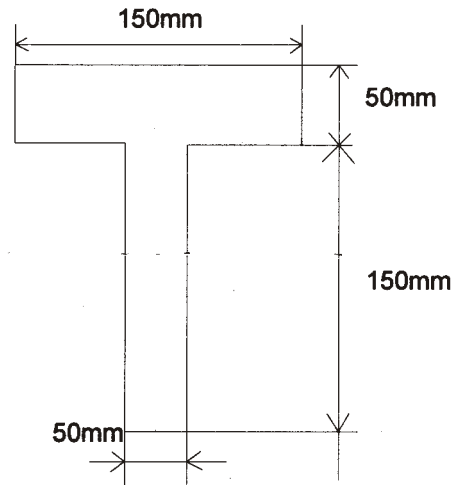

- 14.** (a) Determine the horizontal and vertical components of a force of 150 N acting on a rigid body at an angle of 20° with the horizontal.
- (b) In a rectangular lamina $100 \text{ mm} \times 120 \text{ mm}$ a rectangular opening $PQRS$ $30 \text{ mm} \times 40 \text{ mm}$ is made as shown in the figure below. Find the centroid of the lamina :

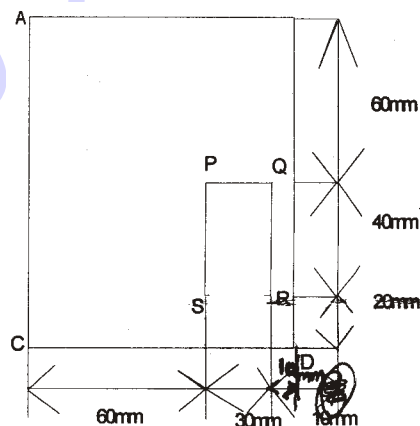

- * **15.** A piston moving with SHM has a velocity of 4 m/s, when it is 2 meters from the centre. Find (a) amplitude, (b) periodic time, (c) maximum velocity and (d) maximum acceleration.

- * 16. A body is vertically projected upward with a velocity of 7.2 m/s. How long will it take to reach a point 84 m below the point of projection?
17. An effort of 200 N is applied to a lifting machine to raise a load out of which 10% is lost in friction. If VR of the machine is 10, determine (a) the load lifted and (b) efficiency.
18. (a) What are the conditions for maximum MA and maximum efficiency of simple machines?
(b) Explain kinematic pair and kinematic chain with neat sketches.
