



C14-EE-606

4746

**BOARD DIPLOMA EXAMINATION, (C-14)**  
**MARCH/APRIL—2018**  
**DEEE—SIXTH SEMESTER EXAMINATION**  
**INDUSTRIAL AUTOMATION**

Time : 3 hours ]

[ Total Marks : 80

---

**PART—A**

3×10=30

**Instructions** : (1) Answer **all** questions.

(2) Each question carries **three** marks.

(3) Answers should be brief and straight to the point and shall not exceed *five* simple sentences.

1. Define transfer function and state the transfer function of a closed-loop feedback control system.
2. State the disadvantages of open-loop control system.
3. List different output devices used in control systems.
4. State the specifications of potentiometers.
5. State the applications of synchro.
6. Mention the basic elements of block diagram.
7. Write the rules for moving summing point ahead of a block.

- \* 8. Explain time variant and time invariant systems.
9. Draw the ladder diagram for NOR gate and NOT gate.
10. State different parts of PLC.

**PART—B**

10×5=50

**Instructions :** (1) Answer *any five* questions.  
 (2) Each question carries **ten** marks.  
 (3) Answers should be comprehensive and the criterion for valuation is the content but not the length of the answer.

11. Describe closed-loop temperature controller with block diagram. 10
12. (a) Write the force balance equations of mechanical elements and their analogous electrical elements in force current analogy. 5  
 (b) Explain PD controller with block diagram. 5
13. (a) Explain the input devices push button and pressure switch in detail. 5  
 (b) Briefly explain about AC and DC solenoids. 5
14. (a) Explain the working of potentiometer as an error detector. 5  
 (b) Differentiate between hydraulic and pneumatic controllers. 5
15. (a) Explain the working of synchro as control transformer. 5  
 (b) Explain the concept of digital controller. 5

- \* 16. (a) Write five properties of transfer function. 5  
 (b) Find the transfer function for the following network : 5

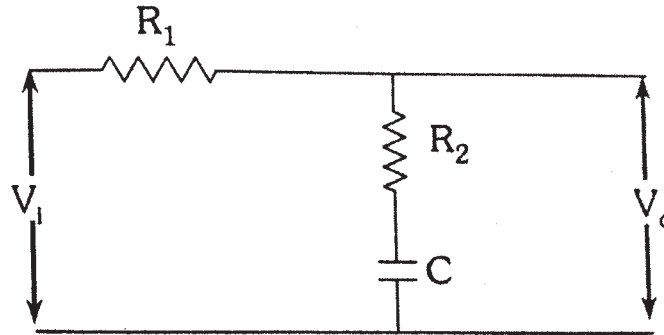

17. (a) State the softwares used in SCADA. 5  
 (b) Draw the ladder diagram of staircase lighting scheme. 5
18. (a) Explain up counter and down counter instructions. 5  
 (b) State the applications of PLC. 5

\*\*\*