



C14-EE/CHPP-107

4044

BOARD DIPLOMA EXAMINATION, (C-14)

OCT/NOV—2016

DEEE—FIRST YEAR EXAMINATION

ENGINEERING DRAWING

Time : 3 hours]

[Total Marks : 60

PART—A

5×4=20

Instructions : (1) Answer **all** questions.

(2) Each question carries **five** marks.

(3) All dimensions are in mm.

1. Print the following in 10 mm size, vertical single-stroke capital lettering :

POLYCET IS AN ADMISSION TEST FOR POLYTECHNICS

2. Redraw the following figure and dimension it properly using parallel dimensioning :

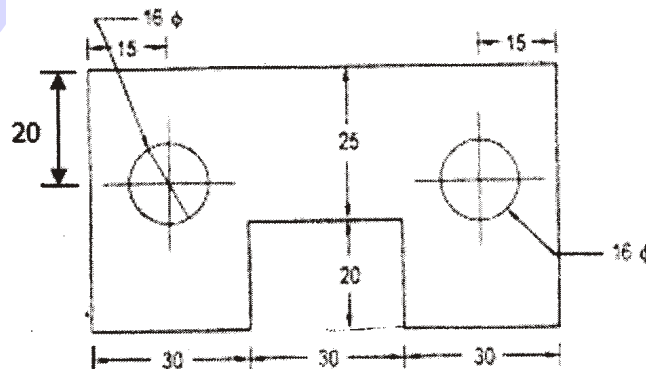

*

3. Draw an auxiliary view for the inclined surface of the object given below :

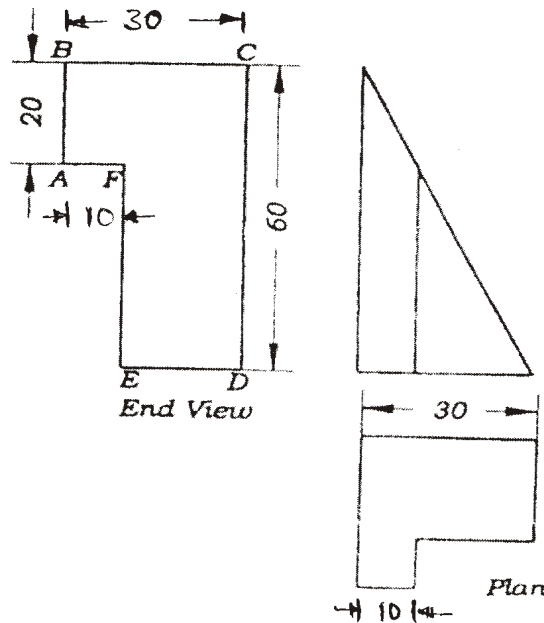

4. Draw a common external tangent to two circles of radii 25 mm and 20 mm. The distance between the centers of circles is 75 mm.

PART—B

10×4=40

- Instructions :** (1) Answer any **four** questions.
(2) Each question carries **ten** marks.
(3) All dimensions are in mm.

5. Construct a cycloidal curve through a point on the circumference of a circle of diameter 30 mm for one complete revolution.

6. A regular hexagon of side 25 mm has its one edge on HP. The surface of the plane is perpendicular to VP and inclined at 45 degrees to HP. Draw the projections of the plane.

- * 7. Draw the front view, top view and side view of the following object :

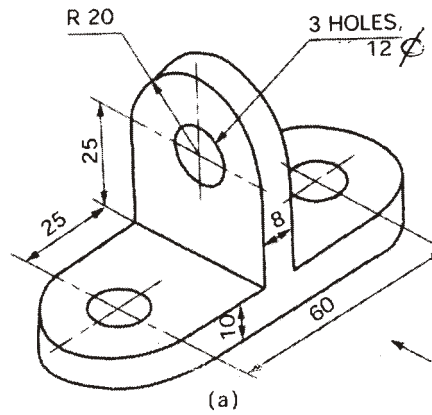

8. A cone of base 60 mm dia and height 80 mm is resting on ground with its base. It is cut by a section plane perpendicular to VP, inclined at 45 degrees to HP and cutting the axis at point 50 mm from the base. Draw the front view and sectional top view.
9. Draw an isometric view for the following orthographic projections :

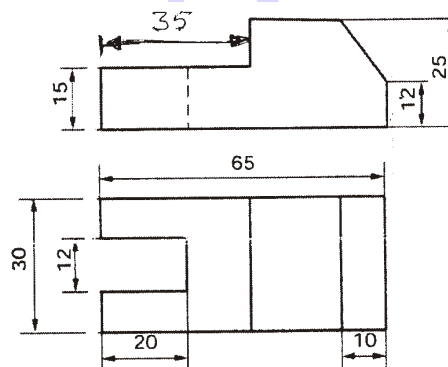

10. Draw the development of lateral surface to truncated cylinder (part P) as shown below :

