



C09-EE-303

3241

BOARD DIPLOMA EXAMINATION, (C-09)
OCT/NOV—2016
DEEE—THIRD SEMESTER EXAMINATION
ELECTRICAL CIRCUITS

Time : 3 hours]

[Total Marks : 80

PART—A

3×10=30

- Instructions** : (1) Answer **all** questions.
(2) Each question carries **three** marks.
(3) Answers should be brief and straight to the point and shall not exceed *five* simple sentences.

1. Define the following terms : 1×3=3

- (a) Lumped parameters
(b) Distributed parameters
(c) Mesh of an electric network

2. State Thevenin's theorem. 3

3. Define angular velocity and express the value in terms of frequency. 3

4. In the equations, $V_m = V \cos ZQ$, $V = 100 \angle 0$ volts, $Z = 10 \angle 60$ and $Q = 8 \angle 30$ amp, express V_m in polar. 3

*

5. Two currents are given by the expressions $i_1 = 10 \sin(314t + 45^\circ)$ amp, $i_2 = 8 \sin(314t + 60^\circ)$ amp. Find $i_1 + i_2$ and represent in the similar form. 3
6. Define Q-factor of series resonant circuit. 3
7. Show that the power consumed in an R-L series circuit is $VI \cos \phi$, from the instantaneous equations of voltage and current. 3
8. Two circuits having impedances of $Z_1 = (6 - j8)$ and $Z_2 = (10 + j8)$ are connected in parallel across an a.c. supply. Calculate the admittance of the combination. 3
9. Prove that the current flowing in a neutral wire of a balanced 3- star-connected load is zero. 3
10. The phase voltage of a 3-phase, 5 MVA star-connected alternator is 6500 volts. Calculate (a) the line voltage and (b) full-load line current of the alternator. 1+2=3

PART—B

10×5=50

- Instructions :** (1) Answer **any five** questions.
 (2) Each question carries **ten** marks.
 (3) Answers should be comprehensive and the criterion for valuation is the content but not the length of the answer.

11. Find the current supplied by the battery in the following network using star-delta transformation : 10

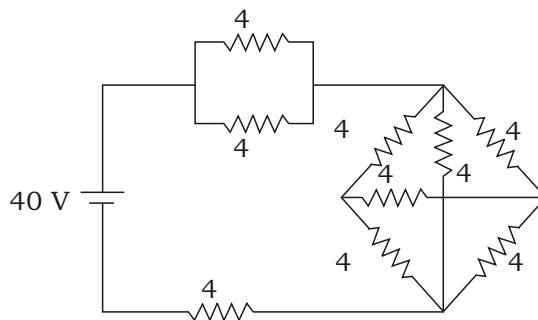

- * **12.** (a) Explain superposition theorem. 3
- (b) Find the current in the 4 Ω resistor of branch AB of the network shown in the following figure by using superposition theorem : 7

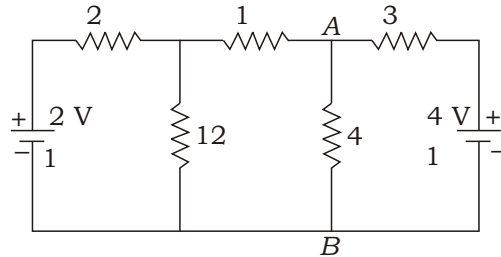

- 13.** (a) Calculate the RMS and average values of half-rectified sinusoidal voltage. 5
- (b) A sinusoidal current wave is given by $i = 75 \sin 100 t$. Determine (i) average value, (ii) RMS value, (iii) form factor and (iv) peak factor. 5

- 14.** An $R-L$ circuit takes a current of 3 A at a p.f. of 0.6 lag when connected to 115 V, 50 Hz supply. Another $R-C$ circuit takes a current of 5 A at a p.f. of 0.77 lead when connected to the same supply. If the two circuits are connected in series across 230 V, 50 Hz supply, then calculate the (a) current, (b) power consumed and (c) p.f. of the total circuit. 3+4+3=10

- 15.** (a) Derive an expression for impedance of an AC circuit consisting of resistance and a pure capacitor in series. Draw also the vector diagram. 5
- (b) A capacitor of 50 F is connected in series with a resistor of 100 Ω. The combination is connected across a 230 V, 50 Hz AC supply. Calculate the (i) impedance, (ii) current, (iii) power factor, (iv) active power and (v) reactive power. 1+1+1+1+1=5

- * **16.** (a) The current flowing through a pure inductor is 20 A. Find the inductance and power consumption, when the voltage applied across the inductor is $V = 200 \sin 314t$. 5
- (b) Show that the power consumed by a pure inductor is zero, when AC supply is applied to it. 5

*

17. A star-connected balanced load is supplied from a 3- balanced supply with a line voltage of 440 V, 50 Hz. Each phase load consists of a resistance and an inductor in series. Take resistance per phase as 15 Ω , inductance per phase as 0.2 H. Find (a) phase current, (b) line current, (c) power factor, (d) active power and (e) reactive power. 2+2+2+2+2=10

18. (a) Determine the value of R for maximum power in the resistance as shown in the figure below and also calculate the power delivered under these conditions : 2+2+2=6

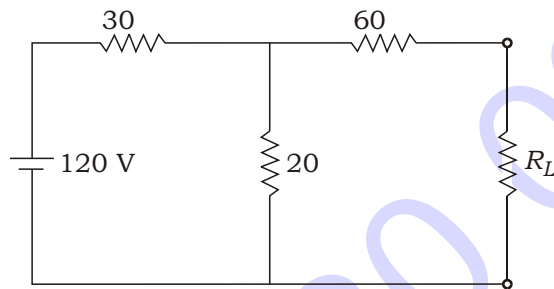

(b) Explain resonance in parallel circuits and derive an expression for resonant frequency. 4
