



7243

BOARD DIPLOMA EXAMINATION, (C-20)

JUNE/JULY—2022

DECE - THIRD SEMESTER EXAMINATION

NETWORK ANALYSIS

Time : 3 hours ]

[ Total Marks : 80

PART—A

3×10=30

- Instructions :**
- (1) Answer **all** questions.
  - (2) Each question carries **three** marks.
  - (3) Answers should be brief and straight to the point and shall not exceed five simple sentences.

1. Define the terms branch, junction and loop in circuits.
2. Determine the number of mesh equations required to solve the given network.

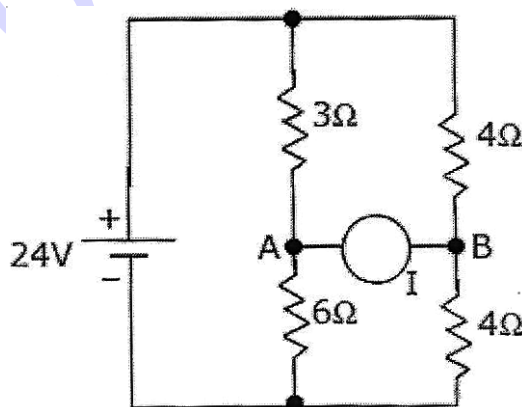

3. Three resistances of  $20\ \Omega$ ,  $40\ \Omega$  and  $60\ \Omega$  are connected in delta. Find the equivalent star-connected resistances.

4. Mention the concept of duality.
5. State any three conditions for series resonance.
6. Compare any three parameters for series and parallel resonance.
7. Define Laplace transform.
8. Define the terms (a) initial condition, (b) steady state and (c) transient state.
9. Compute the Laplace transform of the function  $f(t) = 2u(t - 3)$ .
10. Define the terms (a) characteristic impedance and (b) propagation constant.

**PART—B**

8×5=40

- Instructions :**
- (1) Answer **all** questions.
  - (2) Each question carries **eight** marks.
  - (3) Answers should be comprehensive and criterion for valuation is the content but not the length of the answer.

11. (a) Solve for mesh currents using Cramer's rule for the given network below :

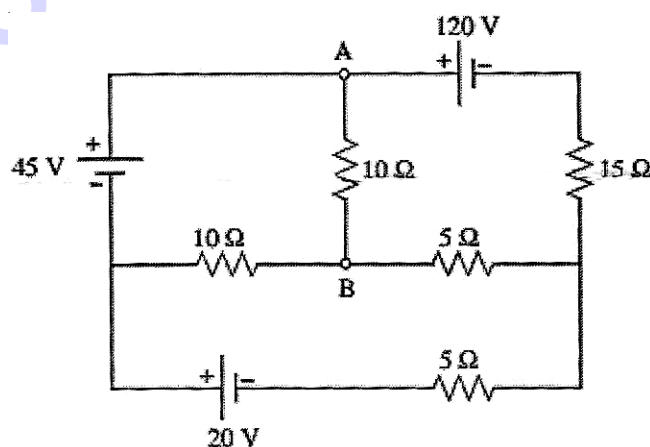

\*

( OR )

- (b) Find  $V_A$  and  $V_B$  for the circuit shown below using Node Voltage Analysis :

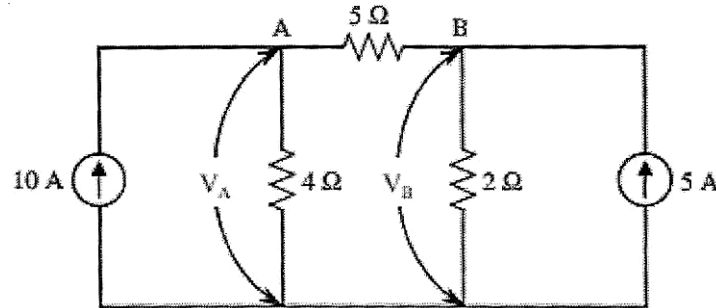

12. (a) Find the current through  $10 \Omega$  resistor using Thevenin's theorem :

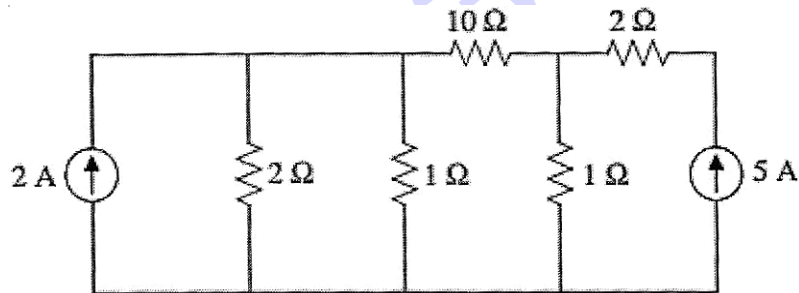

( OR )

- (b) Find the current through  $23 \Omega$  resistor by using superposition theorem :

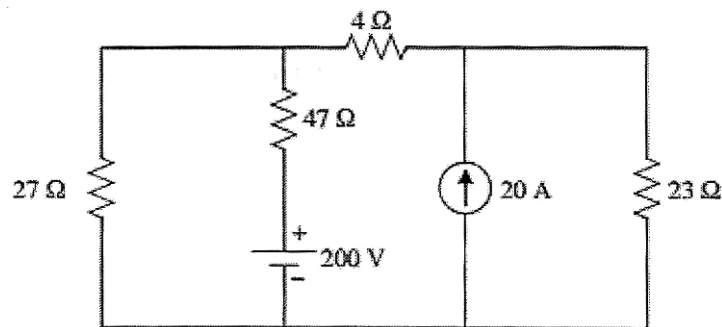

\*

\*

13. (a) A circuit having a resistance of  $4.0 \Omega$  with an inductance of  $0.5 \text{ H}$  and a variable capacitance in series, is connected across a  $100 \text{ V}$ ,  $50 \text{ Hz}$  supply. Calculate (i) the capacitance required to attain resonance; (ii) voltages across the inductance and the capacitance at resonance; (iii) the  $Q$  factor of the circuit.

( OR )

- (b) A coil of  $1 \text{ k}\Omega$  resistance and  $0.15 \text{ H}$  inductance is connected in parallel with a variable capacitor across a  $2.0 \text{ V}$ ,  $10 \text{ kHz}$  a.c. supply as shown. Calculate (i) the capacitance of the capacitor when the supply current is a minimum; (ii) the effective impedance  $Z_r$  of the network at resonance; (iii) the supply current at resonance.

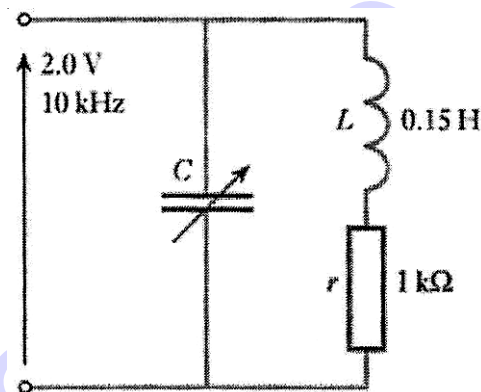

14. (a) Explain the d.c. response of an RLC circuit.

( OR )

- (b) Explain Heaviside's expansion theorem with one example.

- \* 15. (a) Explain T type attenuators with circuit diagram.

( OR )

- (b) Design a high pass filter having a cut-off frequency of  $1 \text{ kHz}$  with load resistance of  $600 \Omega$ .

\*

**PART—C**

10×1=10

- Instructions :** (1) Answer the following question.  
(2) The question carries **ten** marks.  
(3) Answer should be comprehensive and criterion for valuation is the content but not the length of the answer.

**16.** In the circuit of Fig. when  $R = 0 \Omega$ , the current  $i_R$  equals 10 A :

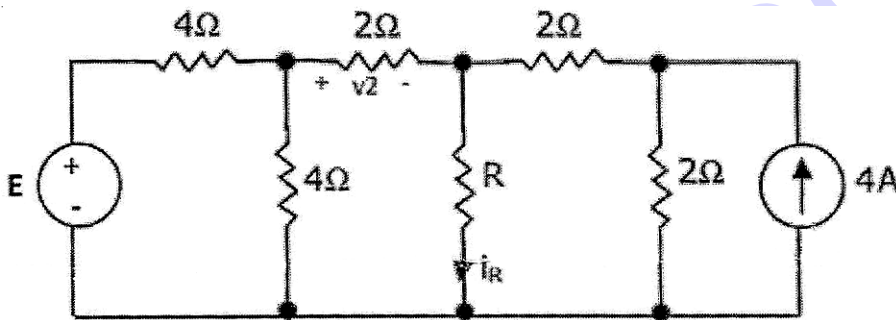

- (a) Find the value of R for which it absorbs maximum power.  
(b) Find the value of E.  
(c) Find  $V_2$  when  $R = \infty$  (open circuit)

\*\*\*

030030030

\*

\*