



C20-EC-CHPC-PET-107

7031

BOARD DIPLOMA EXAMINATION, (C-20)

SEPTEMBER/OCTOBER—2021

DECE - FIRST YEAR EXAMINATION

ENGINEERING DRAWING

Time : 3 hours]

[Total Marks : 60

PART—A

5×4=20

Instructions : (1) Answer **all** questions.

(2) Each question carries **five** marks.

1. Write the following in single stroke capital vertical lettering of size 12 mm.

“SEMESTER PRODUCTION DRAWING”

2. Redraw the following figure to the full scale by correcting the errors in dimensioning as per SP-46 : 1988 :

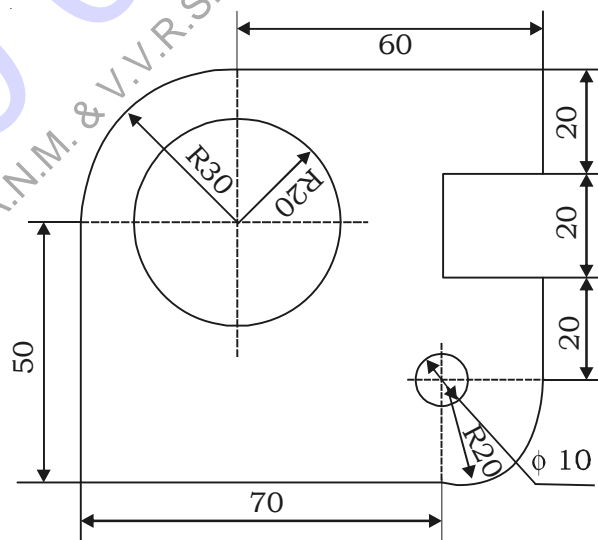

/7031

1

[Contd...

3. Draw an internal tangent to two unequal circles of radii 25 mm and 30 mm. The distance between the centers is 80 mm.
4. For the T-section views are shown below, draw the auxiliary view for the inclined surface :

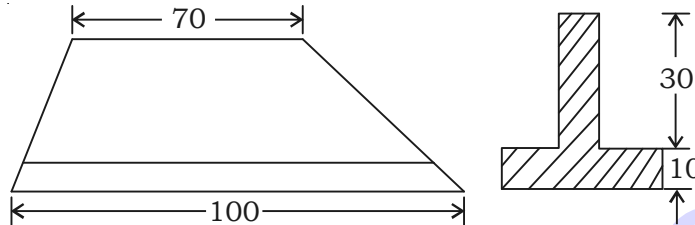

PART—B

10×4=40

Instructions : (1) Answer *any four* questions.
 (2) Each question carries **ten** marks.

5. Draw the involute on an equilateral triangle of side 30 mm.
6. A pentagonal pyramid of base 30 mm and axis 60 mm long has its apex on the VP and the axis perpendicular to VP. A corner of the base is resting on the ground and the side of the base contained by the corner is inclined at 30° to the ground. Draw its projections.
7. A cone of base diameter 40 mm and axis 60 mm is resting on HP with its base and axis 30 mm in front of VP. A section plane cuts it at a distance of 25 mm from apex and parallel to its base. Draw its sectional top view and front view.
8. Draw the front view, top view and right-side view of the following object in first-angle projection :

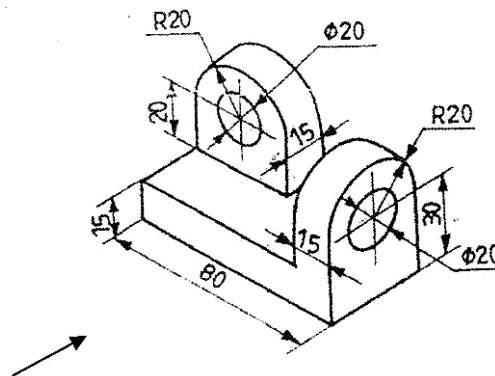

9. Draw the isometric view of the object whose orthographic views are given below :

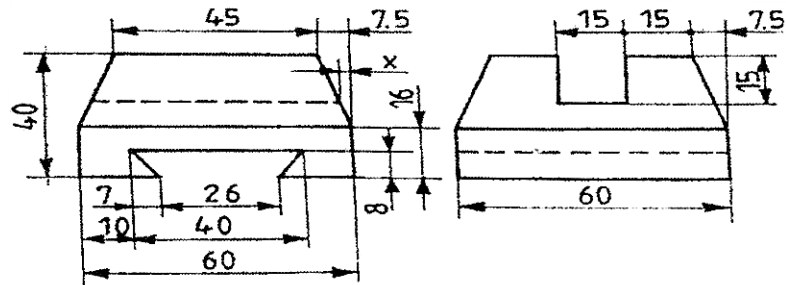

10. A hexagonal prism of base edge 25 mm and height 60 mm, whose rectangular face is parallel to VP. It is cut by an oblique plane at 45° inclined to HP and passing through centre of the axis. Draw the development of the lateral surface of the truncated hexagonal prism.
