



C09-EC-306

3238

**BOARD DIPLOMA EXAMINATION, (C-09)
MARCH/APRIL—2017
DECE—THIRD SEMESTER EXAMINATION
CIRCUIT THEORY**

Time : 3 hours]

[Total Marks : 80

PART—A

3×10=30

- Instructions :** (1) Answer **all** questions.
(2) Each question carries **three** marks.
(3) Answers should be brief and straight to the point and shall not exceed *five* simple sentences.

1. Differentiate between DC and AC.
2. Write the expression for the resonant frequency of the following parallel circuits :
 - (a) L, C
 - (b) RL, C
 - (c) L, RC
3. Find the resonant frequency in the ideal parallel LC circuit shown below :

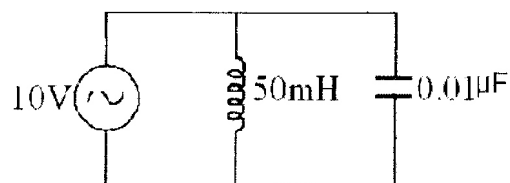

*

4. Define the following terms :

(a) Junction

(b) Branch

(c) Loop

5. Define the following :

(a) Driving point admittance

(b) Transfer admittance

6. In the circuit shown below, find the value of R_L necessary to obtain maximum power in R_L . Also find the maximum power in R_L :

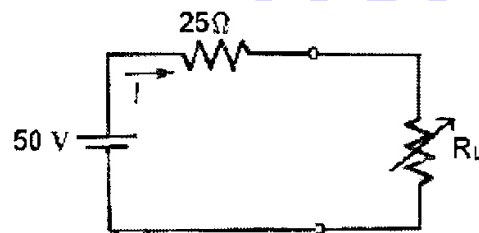

7. A constant current source develops a terminal voltage of 9 V when a 500- resistor is connected across its terminals. What is its terminal voltage, when the 500- resistor is replaced by a 1.5-k resistor?

8. When are double humps formed in the frequency response of a double-tuned circuit?

9. Write the expressions for the following parameters of low-pass RC circuit :

(a) Upper 3dB frequency

(b) Rise time in terms of upper 3dB frequency

10. Draw the high-pass R - C circuit and low-pass R - C circuit.

*

PART—B

10×5=50

- Instructions :** (1) Answer *any five* questions.
 (2) Each question carries **ten** marks.
 (3) Answers should be comprehensive and the criterion for valuation is the content but not the length of the answer.

11. For the circuit shown below, determine the total current, the phase angle and total impedance in the circuit :

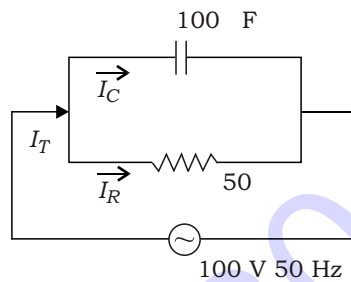

- 12.** (a) Explain the V-I characteristics of a series LC circuit with a.c. source.
 (b) A sinusoidal voltage $v(t) = 100 \sin 100t$ is applied across a pure inductive coil of inductance $L = 0.01$ H. Determine (i) current $i(t)$ and (ii) instantaneous power $p(t)$.
- 13.** Determine the power absorbed by 5 ohm resistor in the circuit shown below by using mesh analysis :

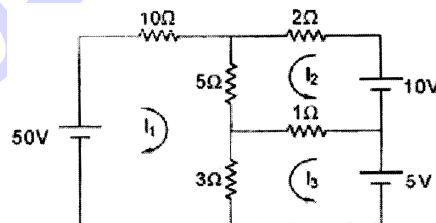

14. Write the node voltage equations for the network shown below and express them in matrix form :

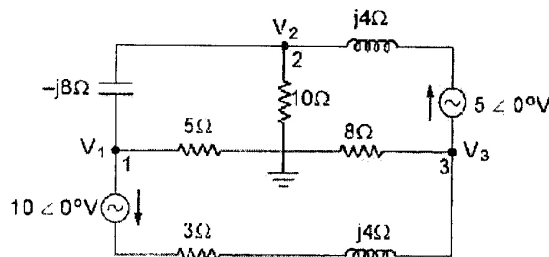

- * 15. Obtain the Norton's equivalent network at AB for the network shown below :

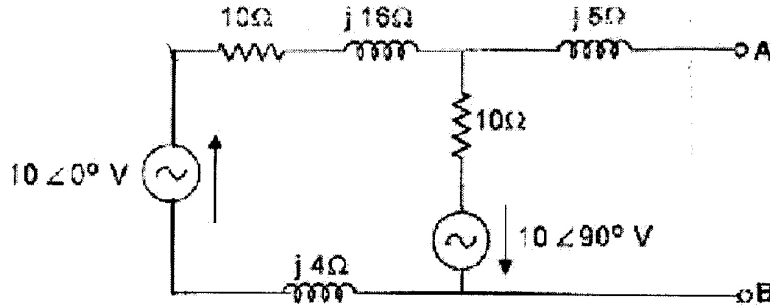

16. By the superposition theorem, calculate the current through the $3 - j4$ impedance branch of the circuit shown below :

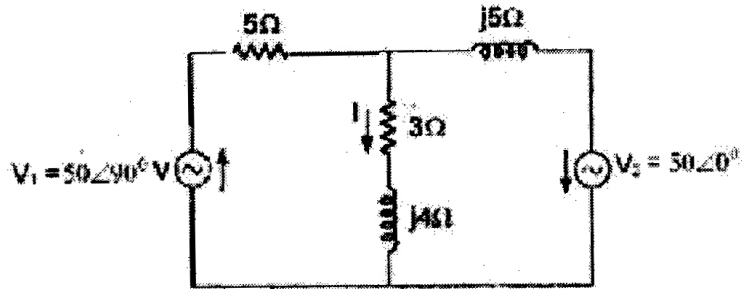

17. Two coils with inductances in the ratio of four to one have coupling coefficient $k = 0.6$. When these coils are connected in series aiding, the equivalent inductance is 44.4 mH . Find L_1 , L_2 and M .
18. The switch in the following figure is closed at $t = 0$. Write the mathematical expressions for $V_L(t)$, $i(t)$ and $V_R(t)$ after the switch is closed :

