



C16-C-107/C16-CM-107

6020

BOARD DIPLOMA EXAMINATION, (C-16)
OCT/NOV—2017

DCE—FIRST YEAR EXAMINATION
ENGINEERING DRAWING

Time : 3 hours]

[Total Marks : 60

PART—A

5×4=20

- Instructions :** (1) Answer **all** questions.
(2) Each question carries **five** marks.
(3) Take suitable scale wherever required.
(4) All dimensions are in mm.

1. Print the following in 10 mm size capital single stroke vertical letters :

ALL THE GLITTERS ARE NOT GOLD

2. Redraw the following figure to the full scale and dimension it as per uni-directional system.

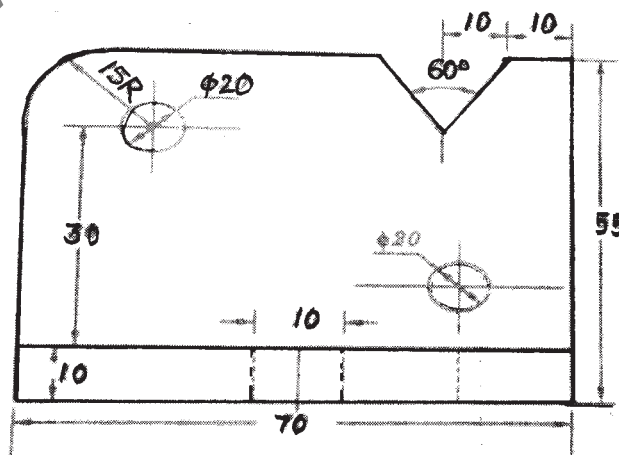

- * 3. Draw a regular hexagon of side 30 mm.
4. Draw the auxiliary view of the sloping side of the object given below :

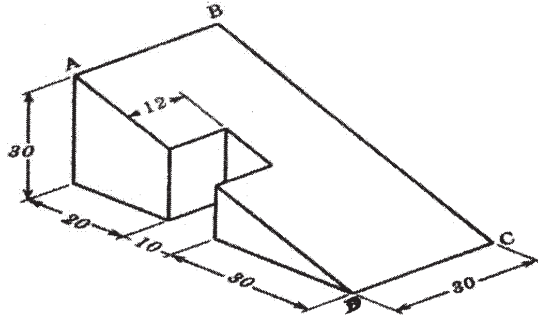

PART—B

10×4=60

- Instructions :** (1) Answer *any four* questions.
 (2) Each question carries **ten** marks.
 (3) Take suitable scale wherever required.
 (4) All dimensions are in mm..

5. Construct an involute of a circle of radius 25 mm.
6. Draw the projections of a regular hexagon of 30 mm side of having one of its sides on the HP and the surface of the plane is perpendicular to VP and inclined at 45 degrees to HP. Draw the projections of the plane.
7. Draw the front view, top view and side vies of the object shown below.

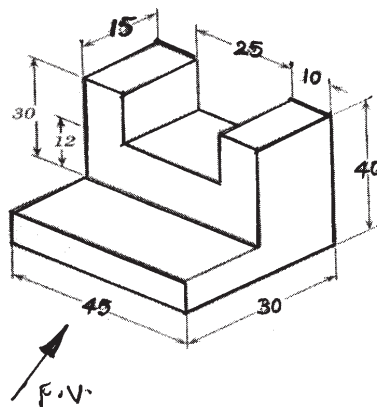

- * 8. Draw the sectional front view, top view and side view of the object shown below.

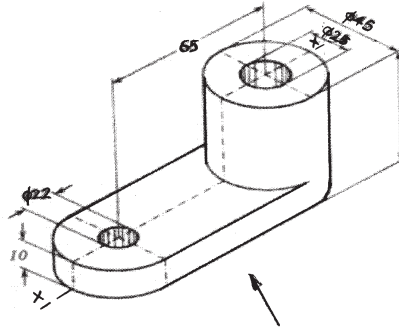

9. Draw an isometric view of an object whose orthographic views are given in the following figure.

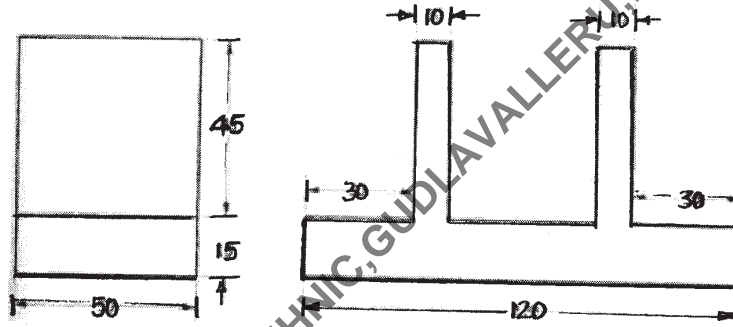

10. A hexagonal pyramid of side of base 30 mm and height 65 mm is resting on its base on HP. One of its base sides is parallel to VP. It is cut by a cutting plane which is parallel to HP and perpendicular to VP and passing through a height of 45 mm from its bottom. Draw the development of the surface.
