

*



C20-C-403

7426

BOARD DIPLOMA EXAMINATION, (C-20)

JUNE/JULY—2022

DCE – FOURTH SEMESTER EXAMINATION

QUANTITY SURVEYING – I

Time : 3 hours]

[Total Marks : 80

PART—A

3×10=30

- Instructions :** (1) Answer **all** questions.
(2) Each question carries **three** marks.
(3) Answers should be brief and straight to the point and shall not exceed five simple sentences.

1. Write the units for the following :
 - (a) Plastering
 - (b) RCC
 - (c) Sand filling
2. Write the formats for preparation of detailed estimation and abstract estimation.
3. Prepare the approximate estimate of proposed construction of building having plinth area of 150 m² and plinth area rate is ₹ 2100.
4. A room has 6·0 m × 4·5 m internal dimensions with 300 mm wall thickness. The basement of cross-section of 400 mm width and 600 mm height. Calculate (a) plinth area and (b) brick masonry in CM (1 : 8) in basement.

*

5. From the accompanying figure. Calculate the following :

- (a) Length of ridge piece
- (b) Length of common rafters
- (c) No. of common rafters

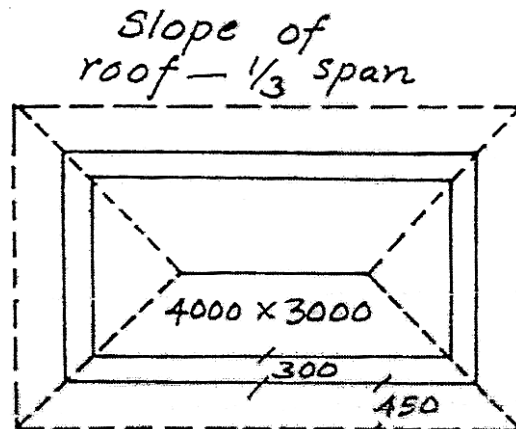

6. Calculate the quantity of cement required in bags for the following items of work :

- (a) CRS Masonry in CM (1 : 6) using granite stone for 15 cum of work if 0.36 cum CM is required for 1 cum Masonry.
- (b) Plastering with CM (1 : 4), 12 mm thick for 100 sqm of work if 0.16 cum of CM is required for 10 sqm of plastering.

7. Write short notes on following terms :

- (a) Blasting charges
- (b) Seigniorage charges
- (c) Cess charges

*

8. Find the cost of bricks at site if the lead is 4 km MR and 3 km CT. Take the rate of bricks per 1000 Nos. as ₹ 1500 at source.

*

9. Define the terms lead and lift used in road formation and give their initial values.
10. Find the volume of earthwork in road embankment of length 1.5 Km, top width is 7.0 m depth 3.5 m and side slopes 2 : 1.

PART—B

8×5=40

- Instructions :** (1) Answer either (a) or (b) from each question.
(2) Each question carries **eight** marks.
(3) Answers should be comprehensive and criterion for valuation is the content but not the length of the answer.

11. (a) Prepare an approximate estimate for a building with a total plinth area of 340 m². Given that

- (i) Plinth area rate ₹ 7500
- (ii) Extra for architecture appearance = 2½% of building cost
- (iii) Extra for Electrical installation = 13% of building cost
- (iv) Extra for water supply and sanitation installation = 6% of building cost
- (v) Contingencies = 3½%
- (vi) Super vision charges = 8%

(OR)

- (b) State and explain the methods of preparing approximate estimates.

12. (a) Prepare the detailed estimate for the following items of work from the Fig-1.

- (i) Cement concrete (1 : 4 : 8) in foundation bed
- (ii) RR masonry in CM 1 : 6 for foundation
- (iii) RCC 1 : 1.5 : 3 for RCC Slab

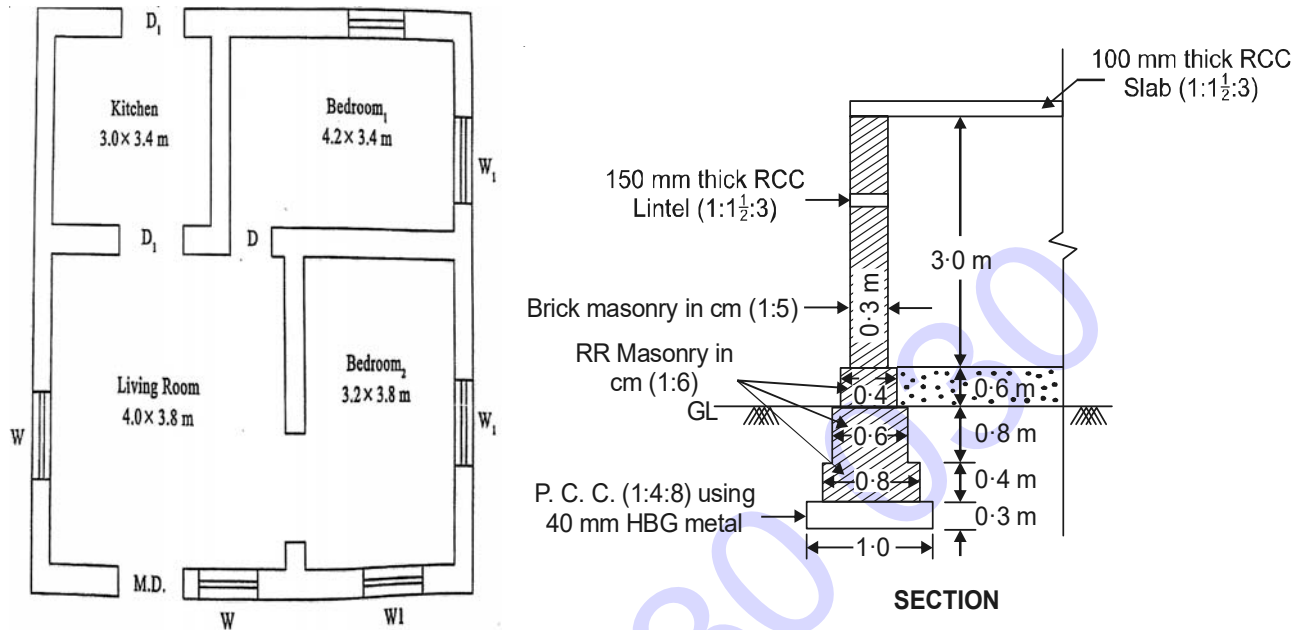

Fig. 1

(OR)

(b) Prepare the detailed estimate for the following items of work from the Fig-1.

- (i) Earth work excavation for foundation
- (ii) Internal plastering in CM 1 : 4 without deduction
- (iii) RR Masonry in CM 1 : 6 for basement

13. (a) For the building shown in Fig. 2, Calculate the quantities of the following items of work :

- (i) RCC (M20) using HBG metal for all column footings
- (ii) Brick Masonry in CM 1 : 4 without deductions

(OR)

(b) For the building shown in Fig. 2, Calculate the quantities of the following items of work.

- (i) RCC (M20) using HBG metal for all columns
- (ii) Plastering in CM 1 : 3 without deductions

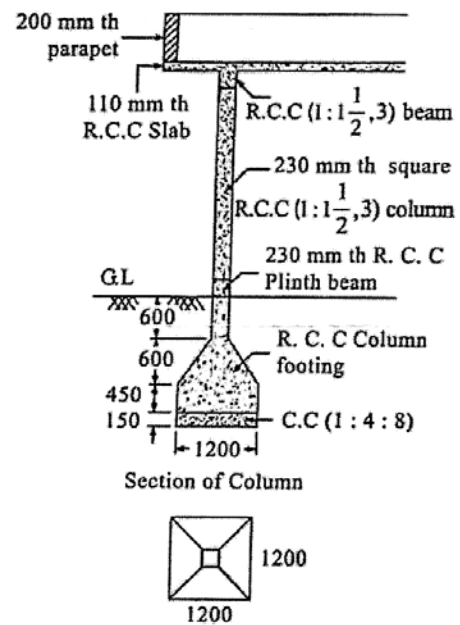
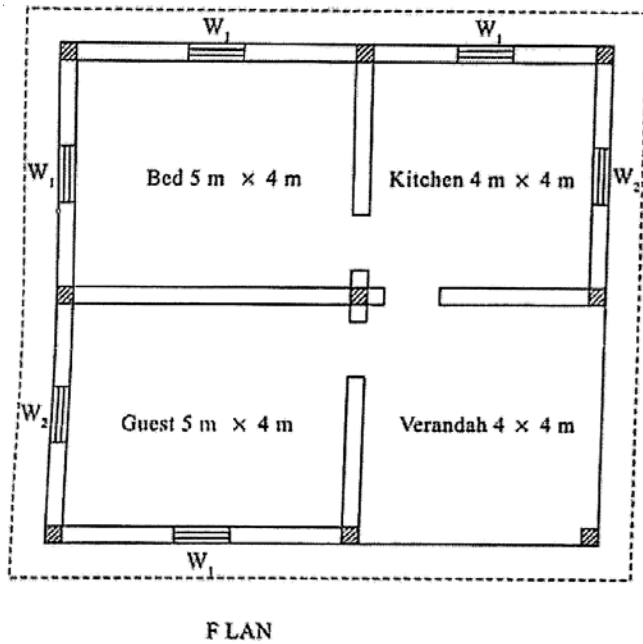

Fig.2

14. (a) Prepare a data sheet and calculate the cost of the items given below :

- (i) Cement concrete (1 : 4 : 8) using 40mm HBG metal—1 m³
- (ii) RR masonry in CM (1 : 6)—1 m³

Materials and labor required for :

Cement concrete (1 : 4 : 8)—1 m	RR masonry in CM (1 : 4)—1 m ³
0.92 m ³ —HBG metal	1.10 m ³ —Rough stone
---- m ³ —Sand	0.34 m ³ —CM (1 : 4)
---- m ³ —Cement	1.80 Nos.—Mason
0.20 Nos.—Mason	2.80 Nos.—Mazdoors
3.20 Nos.—Mazdoors	LS sundries
LS sundries	

*

Lead statement of materials :

Sl. No.	Materials	Rate (₹)	Per	Lead	Conveyance charges
1	40 mm size HBG metal	450	1 m ³	10 km	₹ 14 per 1 km
2	Sand	350	1 m ³	8 km	₹ 12 per 1 km
3	Rough stone	310	1 m ³	5 km	₹ 10 per 1 km
4	Cement	6,800	1 ton	At site	

Labour charges per day:

1. Mason I class = ₹ 440
2. Mason II class = ₹ 420
3. Mazdoor = ₹ 350
4. Hand mixing charges for CM per m³ = ₹ 60

(OR)

(b) Prepare the data sheet and calculate the cost for the following items of work :

(i) RR masonry with CM (1 : 6) unit—1 m³

1.05 m³ Rough stone

0.34 m³ CM (1 : 6)

1.8 Nos. Mason

2.8 Nos. Man mazdoor

LS Sundries

(ii) Pointing to RR masonry in CM (1 : 4) unit—10 m²

0.09 m³ CM (1 : 4)

2.28 Nos. Mason

0.5 Nos. Man mazdoor

1.1 Nos. Woman mazdoor

LS Sundries

*

Lead Statement of Materials :

Sl. No.	Materials	Rate (₹)	Per	Lead	Conveyance charges
1	Rough stone	360	1 m ³	15 km	₹ 12 per 1 km
2	Sand	75	1 m ³	10 km	₹ 13 per 1 km
3	Cement	3600	MT	At site	

Labour Charges :

Mason = ₹ 225.00/day

Men mazdoor = ₹ 180.00/day

Women mazdoor = ₹ 180.00/day

Mixing charges for CM = ₹ 40.00/m³

15. (a) A road in Embankment has the following data :

Chainage (in m)	0	30	60	90	120	150
RL of ground (in m)	30.80	31.25	31.85	32.25	33.00	35.20

Formation level at chainage zero is 33.00 and having a rising gradient of 1 in 120. Top width of formation is 10.5 m and side slope 2H : 1V. Assuming that the transverse slope of the ground is in level, calculate the volume of earth by —

- (i) Trapezoidal formula;
(ii) Prismoid formula.

(OR)

- (b) The contour levels and contour areas of a depression are given below. The bed level of the depression is at 68 m contour and is to be filled up to 74 m. Calculate the earthwork quantity by using :

- (i) Trapezoidal rule
(ii) Prismoidal rule

Contour level (in m)	68	69	70	71	72	73	74
Area of contour (in sq. m)	99	103	110	116	120	132	137

- Instructions :** (1) Answer the following question.
 (2) The question carries **ten** marks.
 (3) Answers should be comprehensive and criterion for valuation is the content but not the length of the answer.

- 16.** Calculate the following quantities of a septic tank shown in Fig. 3.
 (i) CC 1 : 4 : 8 for foundation
 (ii) Brick masonry in CM 1 : 6 for side walls
 (iii) RCC 1 : 2 : 4 for roof cover, Scum board and baffle wall

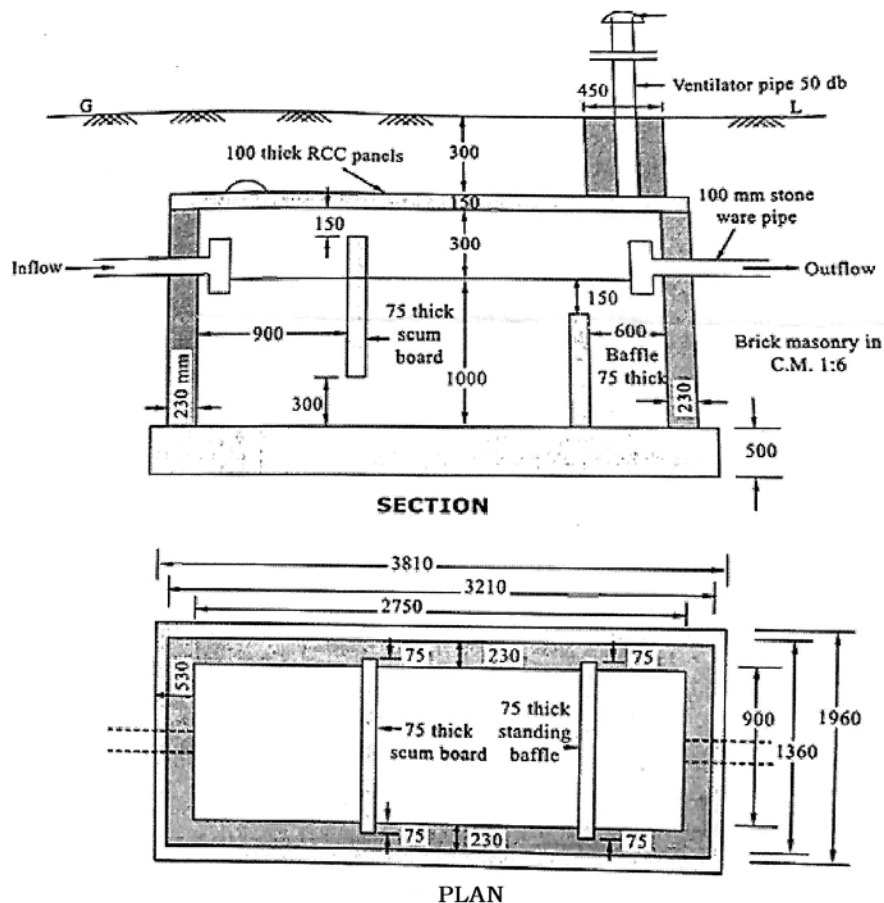

Fig.3

★ ★ ★