



C14-C-507

**4623**

**BOARD DIPLOMA EXAMINATION, (C-14)**

**MARCH/APRIL—2017**

**DCE—FIFTH SEMESTER EXAMINATION**

**CIVIL ENGINEERING DRAWING—II**

*Time : 3 hours ]*

*[ Total Marks : 60*

---

**PART—A**

4×5=20

**Instructions :** (1) Answer **all** questions.

(2) Each question carries **four** marks.

(3) Any missing data may be assumed suitably.

(4) This part need not be drawn to scale.

**1.** Draw the longitudinal section of a head wall in a pipe culvert :

Bottom width = 1200 mm

Top width = 450 mm

Outer face vertical :

Top level of head wall = +52·00

Bottom level of CC bed under head wall = +48·8

Top level of CC bed = +49·10

Width of CC bed = 1800 mm

**2.** Sketch the section at support of an RCC slab bridge showing bed block and abutment cross-section and name the parts.

**3.** Draw section of a water closet (squatting type) along its length.

- \* 4. Name the parts numbered 1 to 4 of the half-plan at top of a surplus weir as shown in the figure below :

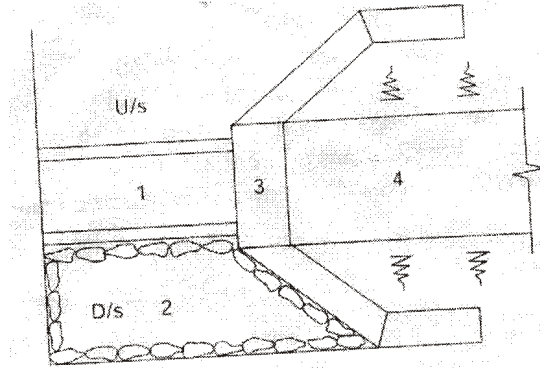

5. Draw the longitudinal section of a canal drop and name the component parts.

### PART—B

**Instructions** : (1) Answer **all** questions.

(2) Any missing data may be assumed suitably.

6. Draw the following views of a septic tank to a scale of 1 : 20 from the given specifications : 10+15=25

(a) Plan

(b) Longitudinal section

*Specifications* :

Internal dimensions = 900 mm 2750 mm

Brick masonry wall thickness = 230 mm

Thickness of CC bed = 500 mm

CC offset for masonry walls = 300 mm

Depth of water = 1000 mm

Free board = 300 mm

Thickness of RCC roof panels = 100 mm and width 450 mm fitted with bent handles for lifting

Scum board = RCC precast slab 75 mm thick fixed at a height of 300 mm from floor level and extending up to a height 150 mm below roof. This shall be fixed at a distance of 900 mm from inside of wall at inflow end into a groove 75 mm deep.

\*

Standing baffle = RCC precast slab 75 mm thick kept on floor at a distance of 600 mm from inside of wall at out flow end. The top of baffle shall be 150 mm below water level.

Inflow and outlet pipes = 100 mm dia. tee shaped pipes.  
Vent pipe = 50 mm dia. AC pipe with a cowl extending to a height of 2.0 m above GL

Masonry pedestal = 450 mm dia. circular brick masonry pedestal shall be provided around the vent pipe up to GL

General ground level = 300 mm above top of RCC precast roof panels.

7. Draw the cross-section of a homogenous earthen bund with the following specifications to a scale of 1 : 50. 15

Top width of bund = 1.5 m

TBL = +57.00

General ground level = +50.00

Stripped ground level = +49.70

Side slopes = 1½ : 1 on U/S and 2 : 1 on D/S

Key trenches = 1.2 m wide and 0.6 m deep at 4.0 m C/C

*Protection of upstream face of the bund :*

The upstream face of the bund is provided with 300 mm thick rough stone revetment over 15 mm thick gravel backing. This revetment is founded on rough stone wall 1.0 m wide 1.0 m deep

*Protection of a downstream toe of the bund :*

A rock toe with 300 mm rough stone boulders is provided with 900 mm top width and top level being at +51.20.

Side slopes of rock toe = 1 : 1

Sand filter = 200 mm thick on rear side and at the bottom of the rock toe

Toe drain = A longitudinal drain is provided with bottom width 1.0 m and side slopes 1 : 1. This is in line with the outer surface of rock toe and taken to a level of +49.00

Rough stones of 300 mm thick are used for side revetment and bed pitching of toe drain

\*\*\*

\*