



C14-C-503

4620

BOARD DIPLOMA EXAMINATION, (C-14)

OCT/NOV—2017

DCE—FIFTH SEMESTER EXAMINATION

QUANTITY SURVEYING—II

Time : 3 hours]

[Total Marks : 80

PART—A

3×10=30

Instructions : (1) Answer **all** questions.

(2) Each question carries **three** marks.

(3) Any data missing may be assumed suitably.

1. State the types of half-turn staircases and draw the rough plan not to scale and show their component parts rough plans only.
2. Calculate the length of a steel rod of 12 mm diameter used in one way slab, given the clear span of slab is 3.2 m, width of supports is 230 mm, thickness of slab is 130 mm and the rod is cranked on one side only. Assume 20 mm cover.

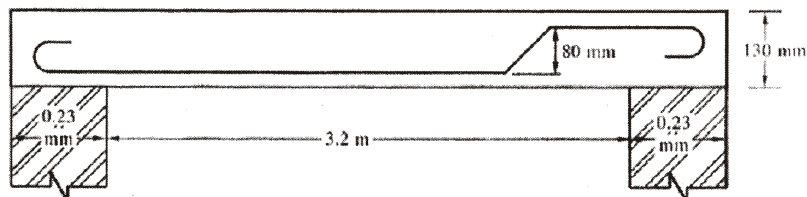

3. Calculate the length of a stirrup of 6 mm diameter for a column of size 300 mm×300 mm. Assume 25 mm clear cover for main reinforcement :

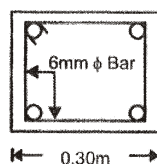

- * 4. What is a standard data book?
5. Calculate the cement required in bags for CC (1 : 5 : 10) using 40 mm HBG metal for 25 m^3 work.
6. Calculate the quantity of cement required in bags for plastering work with CM (1 : 4), 12 mm thick for 40.00 sq.m , if 0.15 m^3 of CM is required for 10 m^2 of plastering.
7. Prepare the detailed estimate for the earthen road of length 100 m of top width 7.5 m and bottom width 8.5 m, height of embankment 0.5 m from the ground.
8. Prepare the detailed estimate of gravel layer of compacted thickness of 150 mm (loose thickness 225 mm) over the already formed earthen road. The width of gravel layer is 4.0 m and length is 600 m.
9. Calculate of quantity of masonry in steining of the following for soak pit :

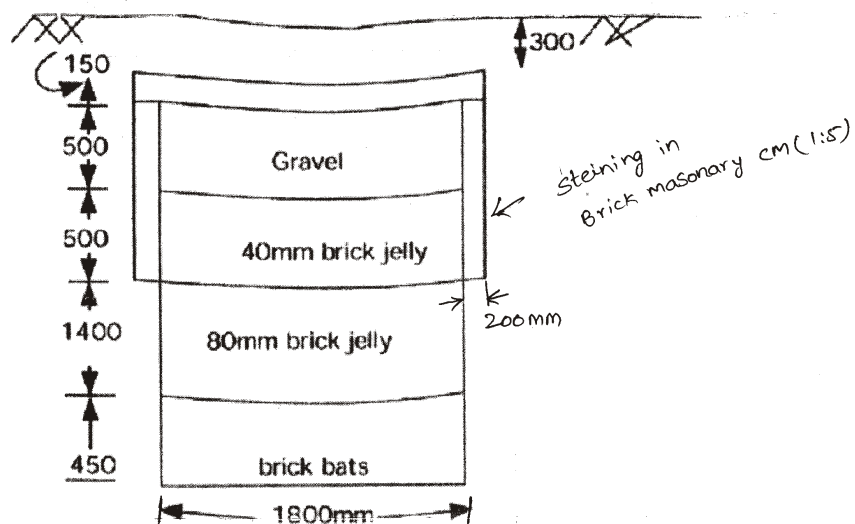

- * 10. The size of the sum board of a septic tank are $1 \text{ m} \times 0.75 \text{ m} \times 0.10 \text{ m}$. Calculate the quantity of plastering.

PART—B

10×5=50

Instructions : (1) Answer *any five* questions.

(2) Each question carries **ten** marks.

(3) Any data missing may be assumed suitably.

11. Prepare a detailed estimate for the following items for a staircase as shown in the figure below :

(a) RCC 1:2:4 f waist slab and landing

(b) Brick masonry in CM 1:6 for steps

(c) Plastering with CM 1:5 for steps

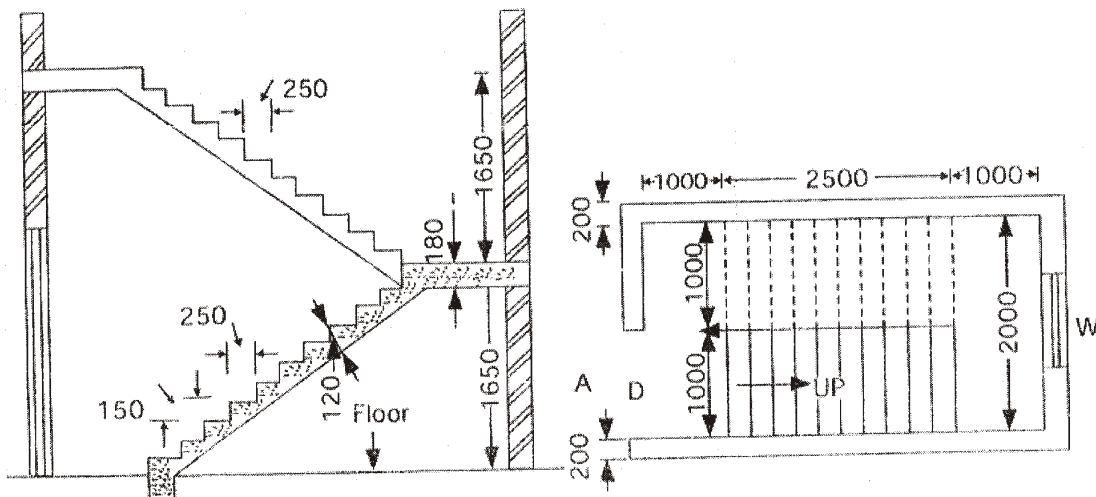

12. Calculate the quantity of steel in RCC square column and footing. Details as shown in the figure below. Size of base 1.00 m×1.00 m×0.23 m. Details the reinforcement.

(a) Mat reinforcement—10 mm diameter bars at 10 cm centre-to-centre in the both sides

(b) 12 mm diameter of vertical bars 4 no's one no. at each corner with sufficient holding into the base reinforcement length of dowel bars is 600 mm

- (c) 6 mm diameter ties as 15 cm centre-to-centre
- (d) The size of the column is 0.23 m×0.23 m

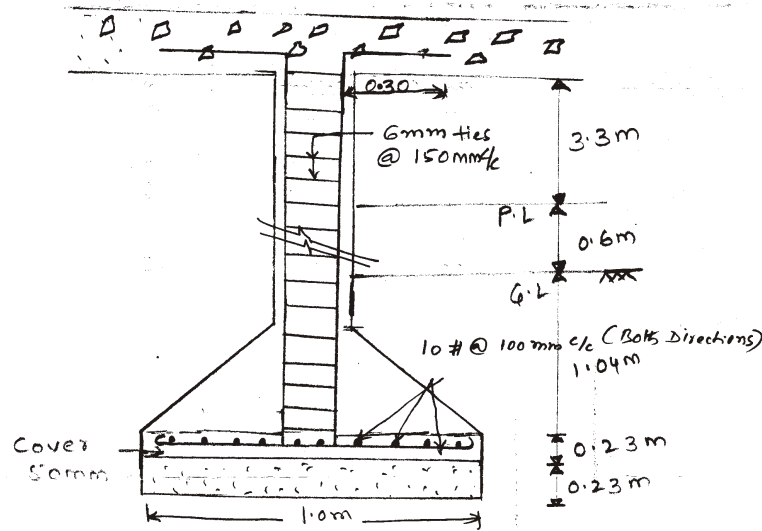

Covers : 30 mm for all bars

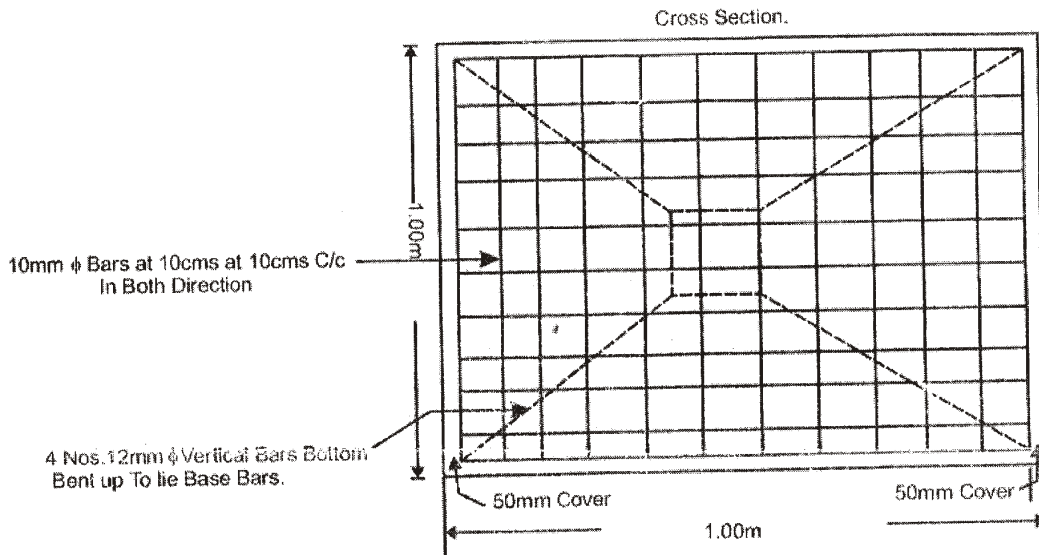

- * **13.** Prepare a data sheet and calculate the cost of the items given below :

(a) Cement concrete (1 : 4 : 8) using 40 mm HBG metal— 1 m^3

(b) RR masonry in CM (1 : 6)— 1 m^3

Materials and labour required for 1 m^3 :

CC (1 : 4 : 8)	RR Masonry in CM (1 : 6)
0.92 m^3 HBG metal	1.10 m^3 rough stone
0.48 m^3 sand	0.34 m^3 CM (1 : 6)
0.115 m^3 cement	1.8 nos. mason
0.2 nos. mason 1st class	2.8 nos. mazdoors
3.2 nos. mazdoors	LS sundries
LS sundries	

Lead statement of material :

Sl. No.	Materials	Rate (in ₹)	Per	Lead	Conveyance charges
1	40 mm size HBG metal	1,100.00	1 m^3	10 km MR	₹ 2 per 1 km
2	Sand	400.00	1 m^3	8 km MR	₹ 2 per 1 km
3	Rough stone	16.50	1 m^3	5 km MR	₹ 3 per 1 km
4	Cement	1,200.00	1 tonne	At site	

Labour charges per day :

(1) Mason 1 class = ₹ 500

(2) Mason 2 class = ₹ 450

(3) Mazdoor = ₹ 300

(4) Hand mixing charges of CM per m^3 = ₹ 80

- * **14.** Prepare a data sheet and calculate the cost of the items given below using lead statement.

(a) Cement concrete (1 : 3 : 6) using 40 mm HBG metal— m^3

(b) Brick masonry in CM (1 : 6)— 1 m^3

*

Materials and labour required for 1 m³ :

CC (1:3:6)	Brick masonry in CM (1:6)
0.92 m ³ HBG metal 40 mm size	512 nos. bricks
— m ³ sand	0.20 m ³ CM (1:6)
— m ³ cement	1.40 nos. mason
0.2 nos. mason	0.70 nos. man mazdoors
1.4 nos. women mazdoors	2.10 nos. woman mazdoors
LS sundries	LS sundries

Lead statement of material :

Sl. No.	Materials	Rate (in ₹)	Per	Lead	Conveyance charges
1	40 mm size HBG metal	306.70	1 m ³	15 km	₹ 4 per 1 km
2	Sand	75.00	1 m ³	9 km	₹ 3 per 1 km
3	Bricks	1,200.00	1000 nos.	12 km	₹ 3 per 1 km
4	Cement	3,400.00	1 MT	local	

Labour charges per day :

Mason = ₹ 166 per day

Man mazdoor = ₹ 116 per day

Woman mazdoor = ₹ 106 per day

Scaffolding charges = ₹ 35 per m³

Mixing charges for CM (1:6) per m³ = ₹ 30.00 per m³

15. Prepare the detailed estimate of water bound macadam road of length 1 km with the details shown in the figure below. Treat that the ground level is uniform and there are no difference level and the dips pot holes and ruts do not exist.

(a) Collection and supply of 65 mm HBG metal

(b) Collection and supply of gravel for base course

- (c) Spreading of 40 mm HBG metal
- (d) Spreading of gravel for base course and shoulders

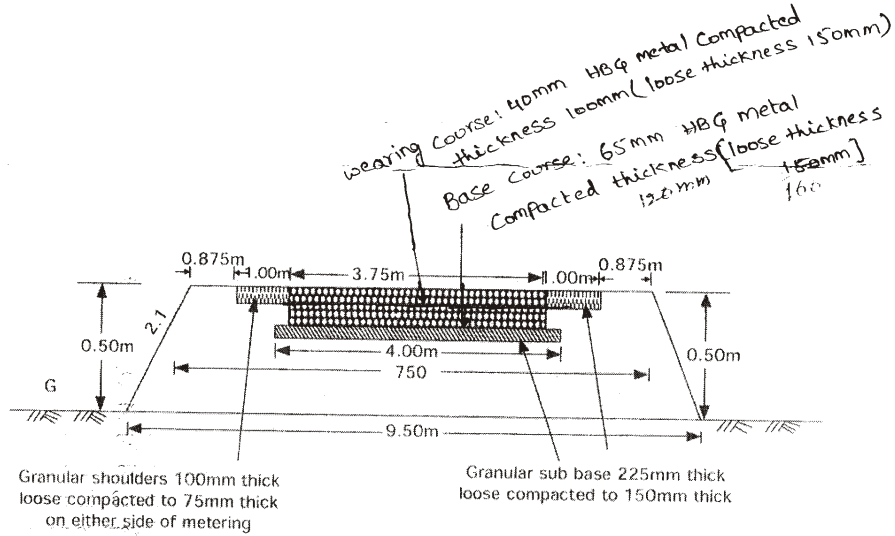

16. For RCC slab culvert shown in the figure below, calculate—
- (a) earthwork excavation for foundation of abutments and return walls;
 - (b) stone masonry in CM (1 : 6) for abutments and return walls;
 - (c) RCC (1 : 15 : 3) required for deck slab.

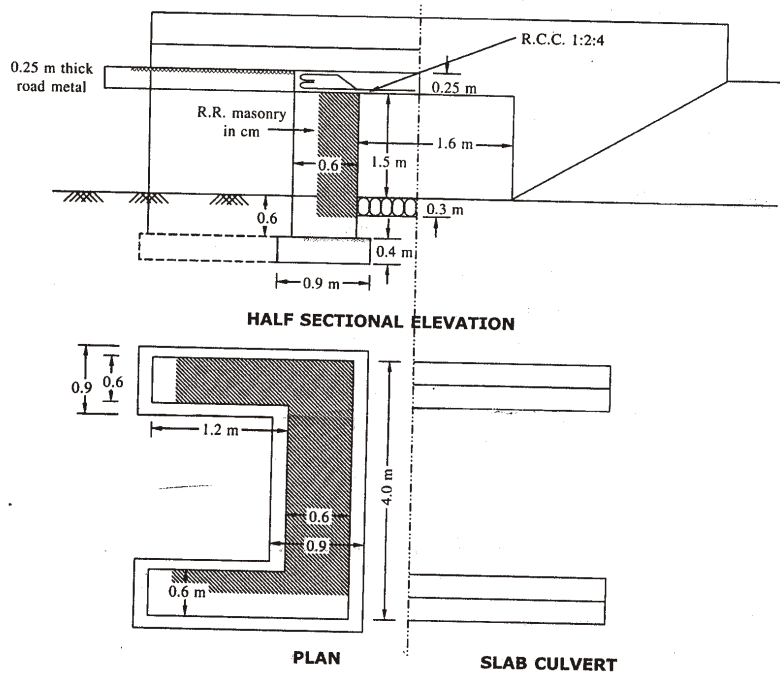

17. Calculate the following quantities for an overhead tank as shown in the figure below :

- (a) Earth work excavation for column foundation
- (b) RCC (1:2:4) for cover slab, bottom slab and side walls.
Thickness of cover slab 150 mm

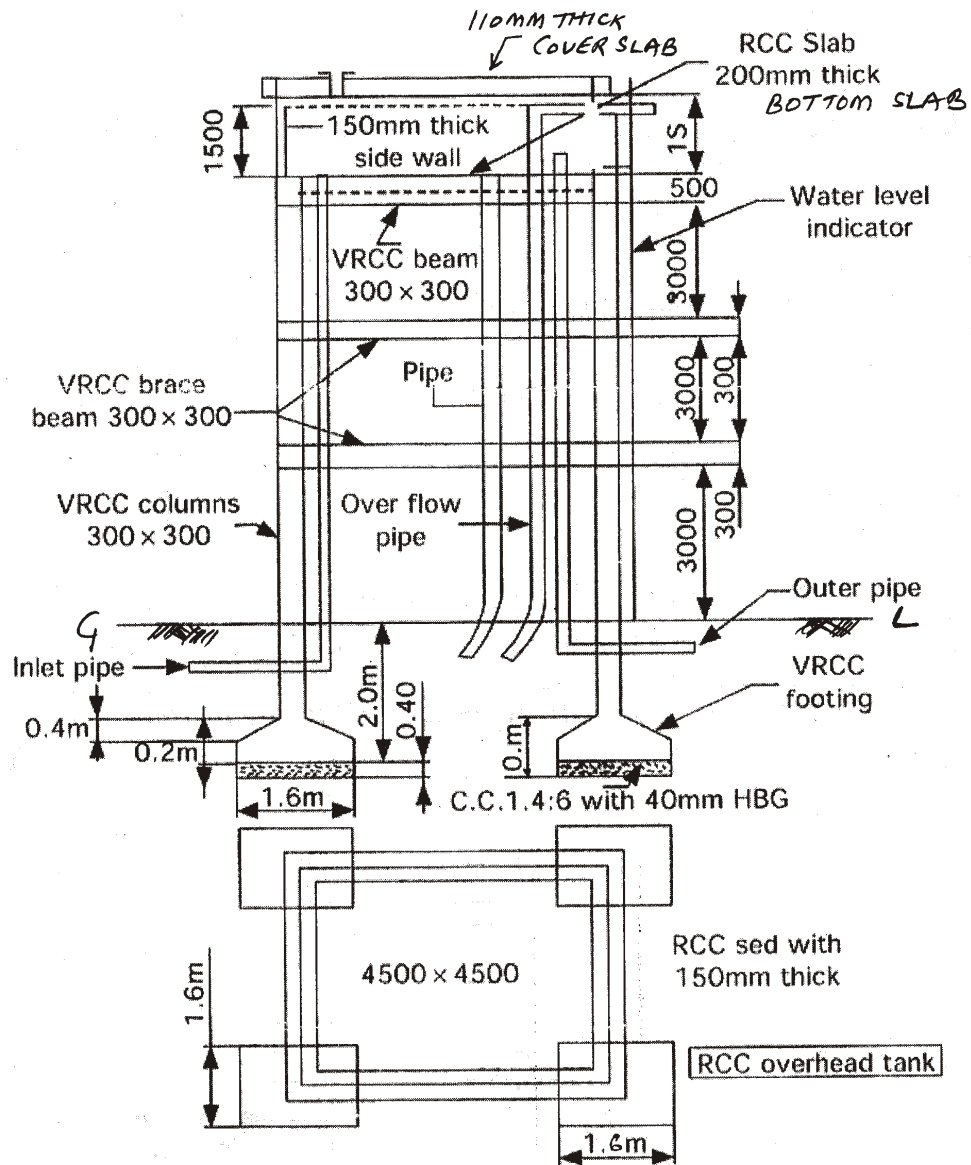

18. Calculate the quantities for the following items of work for an open well shown in the figure below :

- (a) Earthwork excavation for open well
- (b) RR masonry in CM 1:6

