



C14-C-503

4620

BOARD DIPLOMA EXAMINATION, (C-14)

MARCH/APRIL—2017

DCE—FIFTH SEMESTER EXAMINATION

QUANTITY SURVEYING—II

Time : 3 hours]

[Total Marks : 80

PART—A

3×10=30

- Instructions :**
- (1) Answer **all** questions.
 - (2) Each question carries **three** marks.
 - (3) Answers should be brief and straight to the point and shall not exceed *five* simple sentences.

1. Define the term staircase and distinguish between dog-legged staircase and open-well staircase.
2. Distinguish between main reinforcement and distribution reinforcement used in RCC slabs.
3. Calculate the total length of steel rod required for 12 mm dia as shown in Fig. 1. Take all covers 25 mm.

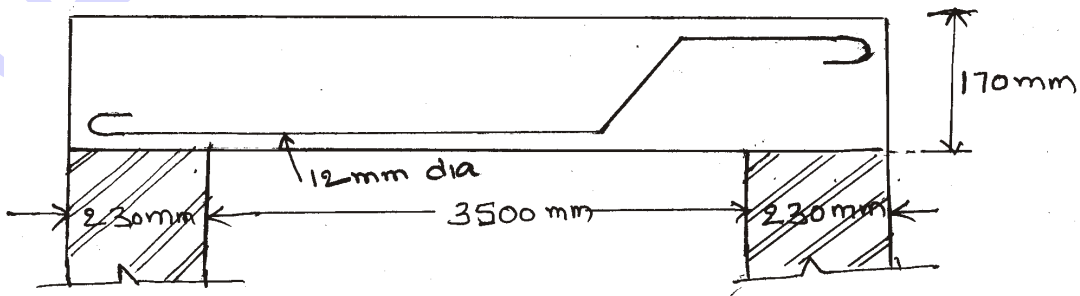

Fig. 1

- * 4. Explain cost of materials at source and cost of materials at site.
5. Write about (a) lead, (b) lead charges and (c) lead statement.
6. Calculate the quantity of cement required in bags for the following items of work :
- (a) CC (1 : 1.5 : 3) using 20 mm HBG metal for 15 m³ of work.
- (b) Plastering with CM (1 : 3) 12 mm thick for 200 m² of work, if 0.20 m³ of CM is required for 10 m² of plastering.
7. The already laid WBM road 3.75 m width found suitable for laying CC pavement of (1 : 3 : 6) mix with 20 mm size HBG chips 110 mm thick over base course of CC (1 : 5 : 10) with 40 mm size HBG chips 150 mm thick. Prepare the detailed quantity of CC pavement and base course for a length of 1 km.
8. The cross-section of head wall of pipe culvert is shown in Fig. 2. Calculate the quantity of RR masonry in CM 1 : 6, if the length of head is 6.0 m.

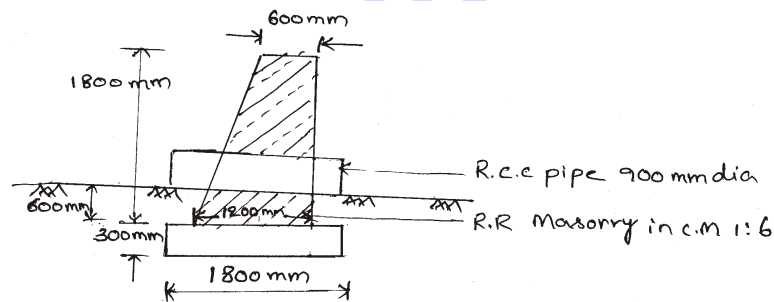

Fig. 2

9. The cross-section of circular dispersion trench 1.60 m dia is shown in Fig. 3. Calculate the quantities of following :
- (a) 40 mm size brick jelly
- (b) Brick masonry for side walls

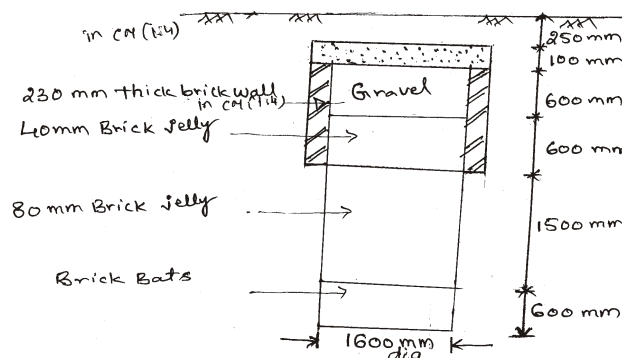

Fig. 3

- * 10. List various items to be included in the abstract estimate open dia walls.

PART—B

10×5=50

- Instructions :** (1) Answer *any five* questions.
 (2) Each question carries **ten** marks.
 (3) Answers should be comprehensive and the criterion for valuation is the content but not the length of the answer.

11. Calculate the quantities of the following items of work for a dog legged staircase as shown in Fig. 4 :
- RCC (1 : 2 : 4) with 20 mm HBG metal for toe wall, waist slab and landing slab
 - Brick masonry in CM (1 : 4) for steps
 - Plastering with CM (1 : 5) for steps and waist slab

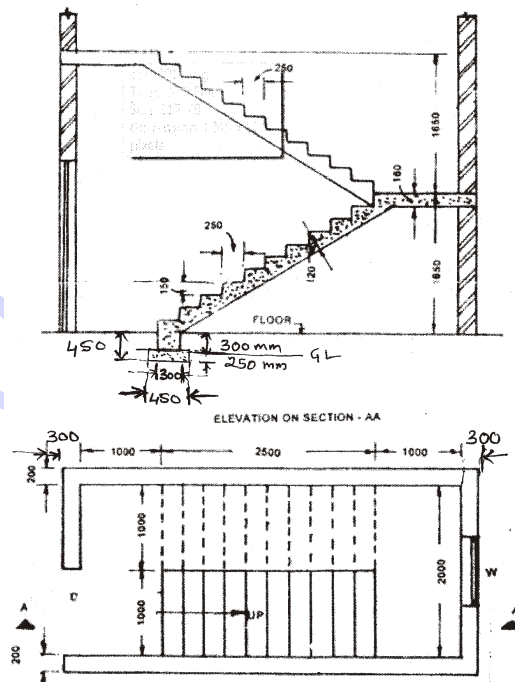

(All dimensions are in mm)

Fig. 4

12. Prepare the bar bending schedule and estimate the quantity of steel for RCC simply supported beam of clear span 4.0 m. The walls supporting the beam are 230 mm with bearing on both sides. Size

of the beam is 230 mm × 450 mm. Concrete cover at ends of bar and sides 30 mm and that of top and bottom is 25 mm each. The reinforcement details of the beam are given below :

Main straight bars at bottom—12 mm, dia.—3 Nos.
 Main bent up bars—12 mm dia.—2 Nos.—cranked at a distance of L/5 from face of supports
 Hanger bars—10 mm—2 Nos.
 Stirrups are 6 mm dia and 150 mm c/c in shearing zone and middle 2.4 m length 210 mm c/c
 Weight of bars : 12 mm—0.89 kg/m; 6mm—0.22 kg/m
 Use Fe 250 grade steel

13. Prepare a data sheet and calculate the cost of the items given below using lead statement :

(a) CC (1 : 3 : 6) using 40 mm HBG metal—1 m³

(b) RR masonry in CM (1 : 6)—1 m³

Materials and labour required for 1 m³ CC (1 : 3 : 6) RR masonry in CM (1 : 6) for 1 m³

0.92 m³ HBG metal 40 mm size
 m³ sand
 m³ cement
 0.20 Nos. masons
 1.40 Nos. Mazdoors
 LS sundries

1.10 m³ rough stone
 0.34 m³ CM (1 : 6)
 1.80 Nos. masons
 2.80 Nos. Mazdoors
 LS sundries

Lead statement of material :

Sl. No.	Materials	Rate	Per	Lead	Conveyance Charges
1.	40 mm HBG metal	450.00	1 m ³	15 km	₹ 20.00/m ³ /km
2.	Sand	120.00	1 m ³	5 km	₹ 15.00/m ³ /km
3.	Cement	4,500.00	1 tonne	local	—
4.	Rough Stone	300.00	1 m ³	10 km	₹ 4.00/m ³ /km

Labour Charges :

Mason I class : ₹ 420 per day
 Mason II class : ₹ 350 per day
 Mazdoor : ₹ 320 per day
 Mixing charges : ₹ 40 per m³

* 14. Explain the following terms :

- (a) Blasting charges
- (b) Seigniorage charges
- (c) Cess charges
- (d) Stacking charges
- (e) Crushing charges
- (f) Water charges

15. A WBM road is proposed to be laid for a length of 2 km as shown in Fig. 5. Prepare a detailed estimate for the following items :

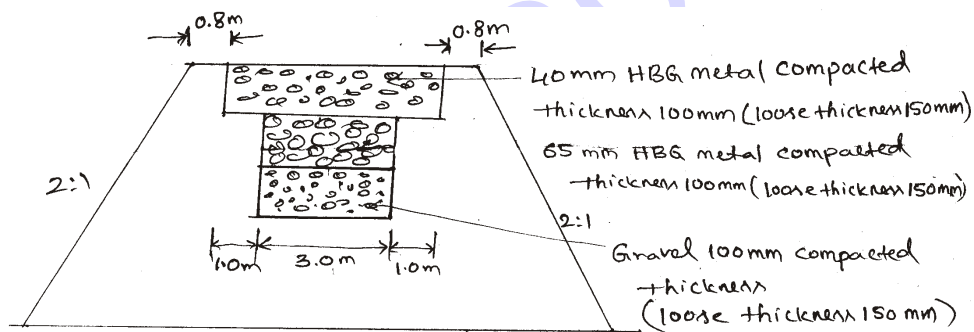

Fig. 5

(a) Collection and supply of the following materials :

- (i) 65 mm HBG metal for base course
- (ii) 40 mm HBG metal for wearing course
- (iii) Gravel for base course
- (iv) Sand for blindage we wearing course to a thickness of 6 mm

(b) Spreading of metal

- (i) Spreading of 65 mm HBG metal
- (ii) Spreading of 40 mm HBG metal

The side slopes of 2 : 1 are provided. Depth of embankment at one end is 2 m and the other end is 1 m.

16. Details of pipe culvert are given in Fig. 6. Calculate the quantities of the following items of work.

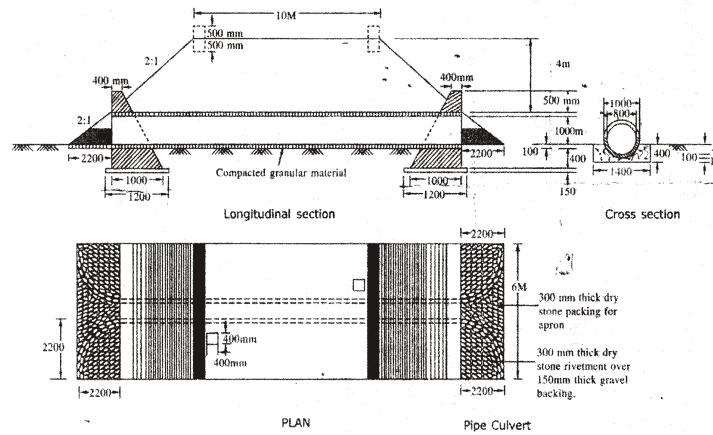

Fig. 6

- Earthwork excavation for foundation under head walls
- Brick masonry in CM (1 : 3) for head walls
- CC (1 : 3 : 6) under head walls

17. Prepare the detailed estimate of the following items of septic shown in Fig. 7.

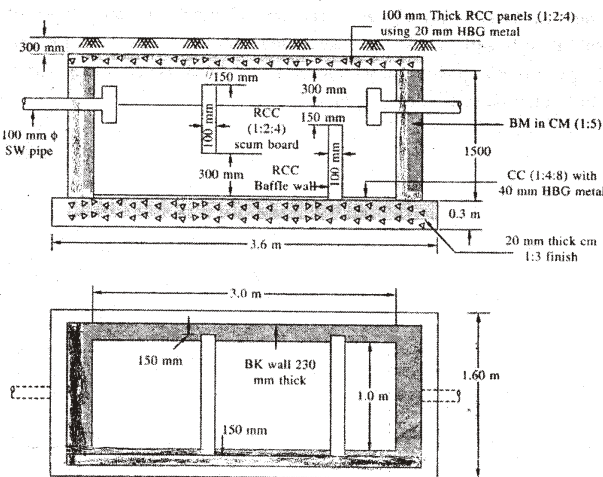

Fig. 7

- Earthwork excavation
- CC (1 : 4 : 8) using 40 mm HBG metal
- Brick masonry in CM (1 : 5)
- RCC work (1 : 2 : 4) with 20 mm HBG for top cover slab

18. Calculate the quantities of the following items of work for tank sluice with tower head as shown in Fig. 8 :

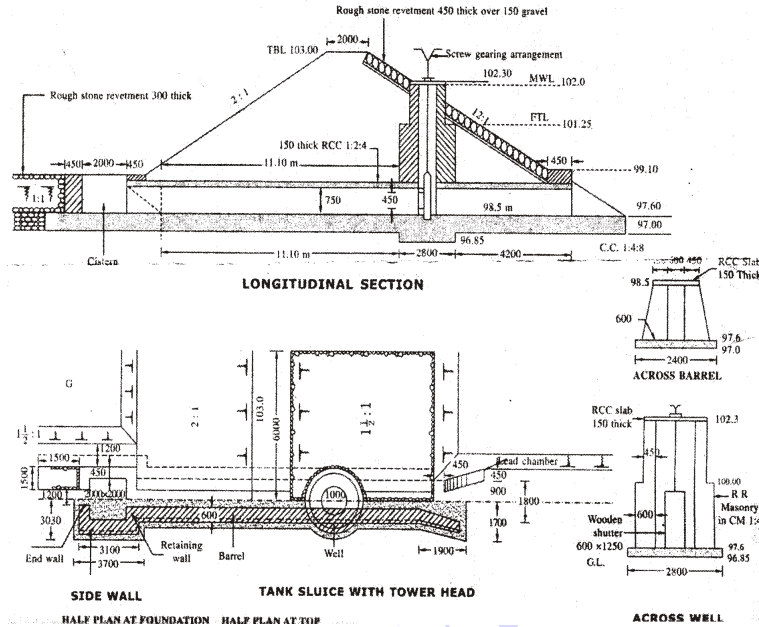

Fig. 8

- CC (1 : 4 : 8) for foundation using 40 mm HBG metal under the Power head.
- RCC (1 : 2 : 4) slab using 20 mm HBG metal for barrel.
- RR masonry in CM (1 : 4) for tower head
