



C14-C-503

4620

BOARD DIPLOMA EXAMINATION, (C-14)

OCT/NOV—2016

DCE—FIFTH SEMESTER EXAMINATION

QUANTITY SURVEYING—II

Time : 3 hours]

[Total Marks : 80

PART—A

3×10=30

Instructions : (1) Answer **all** questions.

(2) Each question carries **three** marks.

(3) Assume any missing data suitably.

1. State the types of staircases.

2. Calculate the length of a cranked (one-side) steel rod of 10 mm diameter, used in one-way slab, given the clear span of slab is 3.2 m, width of supports is 230 mm, thickness of slab is 130 mm :

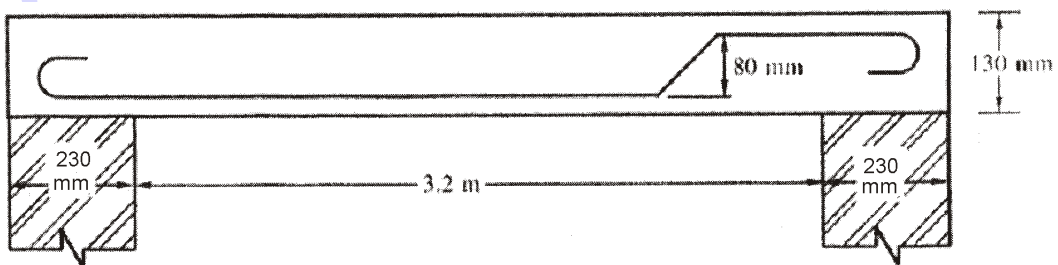

- * 3. Calculate the number of stirrups of 8 mm dia for a simply supported beam of size 200 mm × 350 mm. Spacing of stirrups is 200 mm centre to centre, total length of beam is 5.8 m. Assume end cover of 25 mm :

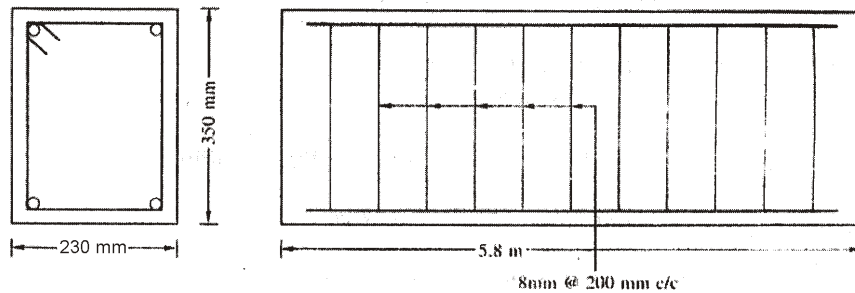

4. Write short notes on the following :
- Seigniorage charges
 - Cess charges
5. Determine the quantity of cement required for 5 cum of RCC 1 : 2 : 4 using 20 mm HBG metal.
6. Calculate the quantity of cement required in bags for plastering work with CM 1 : 3 to RR masonry 40 sq. m. Thickness of plastering is 20 mm.
7. Prepare the detailed estimate of granular shoulders, on either side of WBM road of 800 m. The width of shoulder is 1 m. The compacted thickness is 100 mm (loose thickness 150 mm).
8. Prepare the detailed estimate for the earthen road of length 100 m of top width 7.5 m and bottom width 8.5 m, height of embankment 0.5 m from the ground.
9. The cross-section of circular well is given in the figure below. Calculate the quantity of brick masonry for parapet wall :

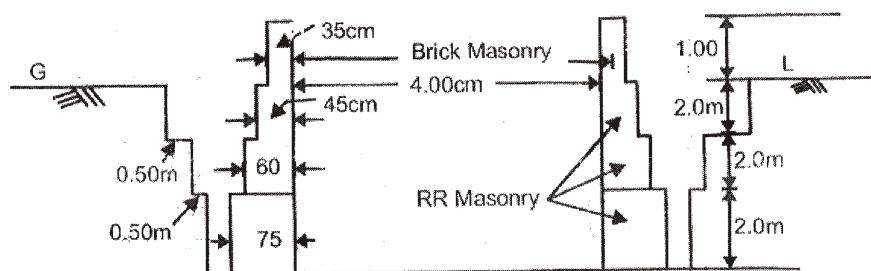

- * **10.** The elevation of VRCC brace of OHSR shown in the figure below. Calculate the VRCC 1 : 2 : 4, if the section at mid-span is 30·45 cm :

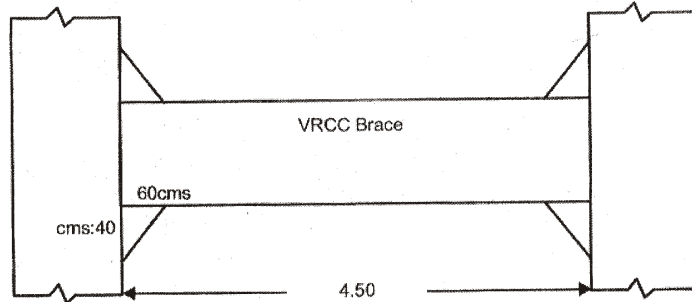

PART—B

10×5=50

- Instructions :** (1) Answer *any five* questions.
 (2) Each question carries **ten** marks.
 (3) Assume any missing data suitably.

- 11.** Prepare a detailed estimate for the following items shown in the figure below :

- (i) RCC 1 : 2 : 4 for waist slab and landing
 (ii) Brick masonry in CM 1 : 6 for steps
 (iii) Plastering with CM 1 : 5 for steps

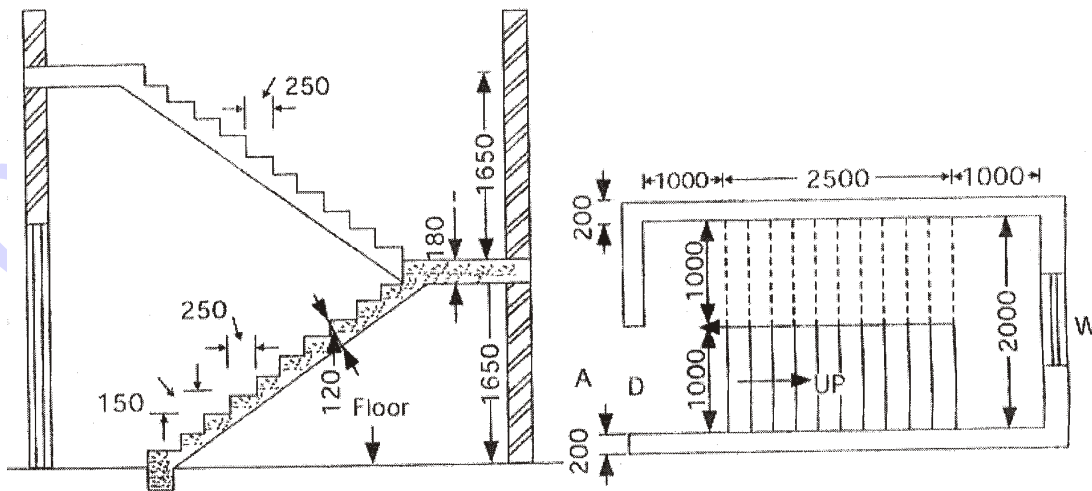

12. Work out the quantities of steel of RCC beam used over a clear span of 5.5 m. The walls supporting the beam are 450 mm thick and the beam has 300 mm bearing over the wall on both sides. The size of beam is 250 mm × 550 mm. Concrete cover at ends of bars and sides is 40 mm and that of top and bottom is 30 mm each. The reinforcement in beam is as detailed below :

- (i) Main straight bars at bottom marked as 1, 4; 22 mm diameter—2 nos.
- (ii) Main bent up bars marked as 2, 3; 22 mm diameter—2 nos.
- (iii) Top bars (anchor bars) marked as 5, 6; 16 mm diameter—2 nos.
- (iv) Stirrup bars 8 mm diameter at both ends of 1.50 m long and including bearing on either side at 150 mm centre to centre and middle 2.5 m length at 210 mm centre to centre

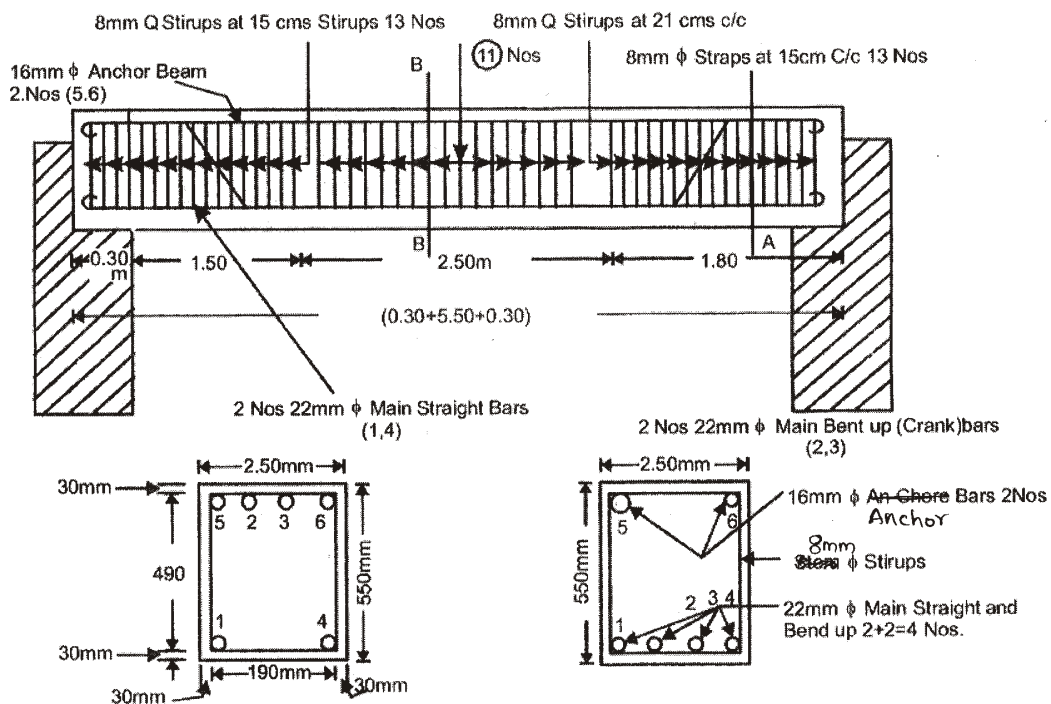

- * **13.** Prepare a data sheet and calculate the cost of the items given below :

- (i) Plain cement concrete (1 : 4 : 8) for foundation—1 m³
(ii) Brick work in CM (1 : 5) using country bricks—1 m³

Materials and labour required for 1 m³ :

PCC (1 : 4 : 8)	Brickwork in CM (1 : 5)
0.92 m ³ HBG metal	600 nos. country bricks
... m ³ sand	0.38 m ³ CM (1 : 5)
... m ³ cement	0.42 nos. mason 1st class
0.06 nos. mason 1st class	0.98 nos. mason 2nd class
0.14 nos. mason 2nd class	0.70 nos. man mazdoors
1.80 nos. man mazdoors	2.10 nos. woman mazdoors
1.4 nos. woman mazdoors	LS sundries
LS sundries	

Labour charges per day and cost of materials at site :

HBG metal 40 mm size—₹ 90/cum

Sand—₹ 50/cum

Cement—₹ 1,400/10 kN

Country bricks—₹ 600/1000 nos.

Mason 1st class = ₹ 35

Mason 2nd class = ₹ 30

Man mazdoor = ₹ 24

Woman mazdoor = ₹ 20

Hand mixing charges of CM per m³ = ₹ 10

*

* **14.** Prepare a data sheet and calculate the cost of the items of works :

(i) RR masonry in CM (1 : 5)—1 m³

(ii) Plastering with 20 mm thick in CM (1 : 4)—10 m²

Materials and labour required for 1 m³ :

CM (1 : 4)

0.21 cum-CM (1 : 4)
 0.66 nos. mason 1st class
 1.54 nos. mason 2nd class
 0.50 nos. man mazdoors
 3.20 nos. woman mazdoors
 LS sundries

RR Masonry in CM (1 : 5)

1.10 m³ rough stone
 0.34 m³ CM (1 : 5)
 0.54 nos. mason 1st class
 1.26 nos. mason 2nd class
 1.40 nos. man mazdoors
 1.40 nos. woman mazdoors
 LS sundries

Lead statement of material :

Sl. No.	Materials	Rate (₹)	Per	Lead	Conveyance charges
1	40 mm size HBG metal	322.00	1 m ³	14 KM	₹ 3 per 1 m ³ per 1 km
2	Sand	86.00	1 m ³	18 KM	₹ 3.60 per 1 m ³ per 1 km
3	Rough stone	275.00	1 cum	12 KM	₹ 3 per 1 m ³ per 1 km
4	Cement	3,600.00	1 MT	local	₹ 2.00/bag

Labour charges per day :

Mason 1st class—₹ 166

Mason 2nd class—₹ 146

Man mazdoor—₹ 116

Woman mazdoor—₹ 116

Scaffolding charges for brick masonry—₹ 30 per m³

Mixing charges for CM (1 : 5) per m³—₹ 30

15. Prepare the detailed estimate of the following items of work for a water bound macadam road as shown in the figure below for a length of 200 m :

- (i) Collection and supply of gravel for shoulders of loose thickness 150 mm
- (ii) Collection and supply of 65 mm HBG metal for base course of loose thickness 150 mm
- (iii) Spreading of 40 mm HBG metal for wearing course of loose thickness 100 mm

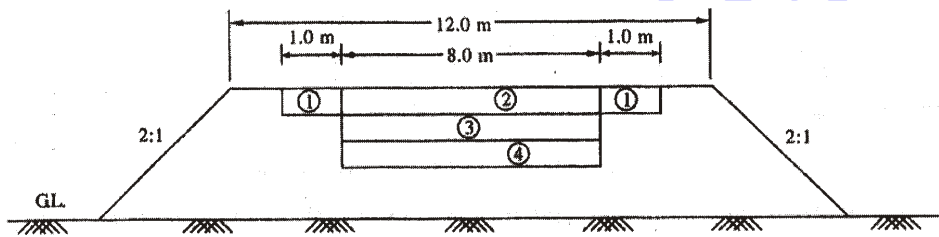

16. Prepare the detailed estimate for the cement concrete road of 1.50 km. Length for the following items of work as shown in the figure below :

- (i) Wearing coat of CC (1 : 2 : 4) with 20 mm size HBG metal 100 mm thick
- (ii) Base course of CC (1 : 4 : 8) with 40 mm size HBG metal compacted thickness of 100 mm (loose thickness of 130 mm)

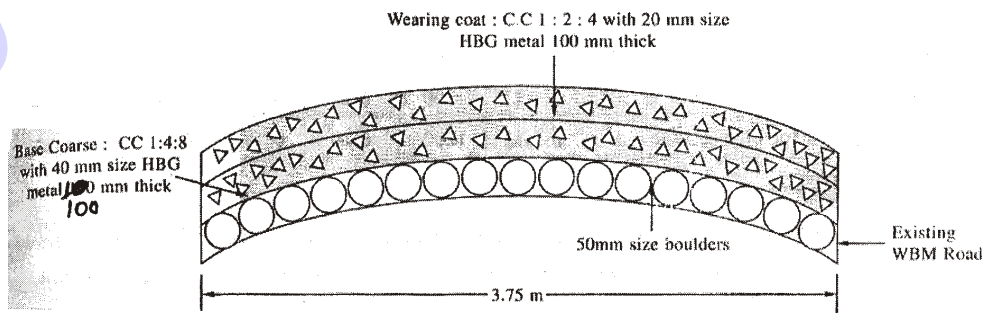

17. Calculate the following quantities for an overhead tank as shown the figure below :

- (i) Earthwork in excavation for foundation of column
- (ii) RCC (1 : 2 : 4) for columns and two brace beams
- (iii) RCC (1 : 1.5 : 4) for cover slab, bottom slab and side walls

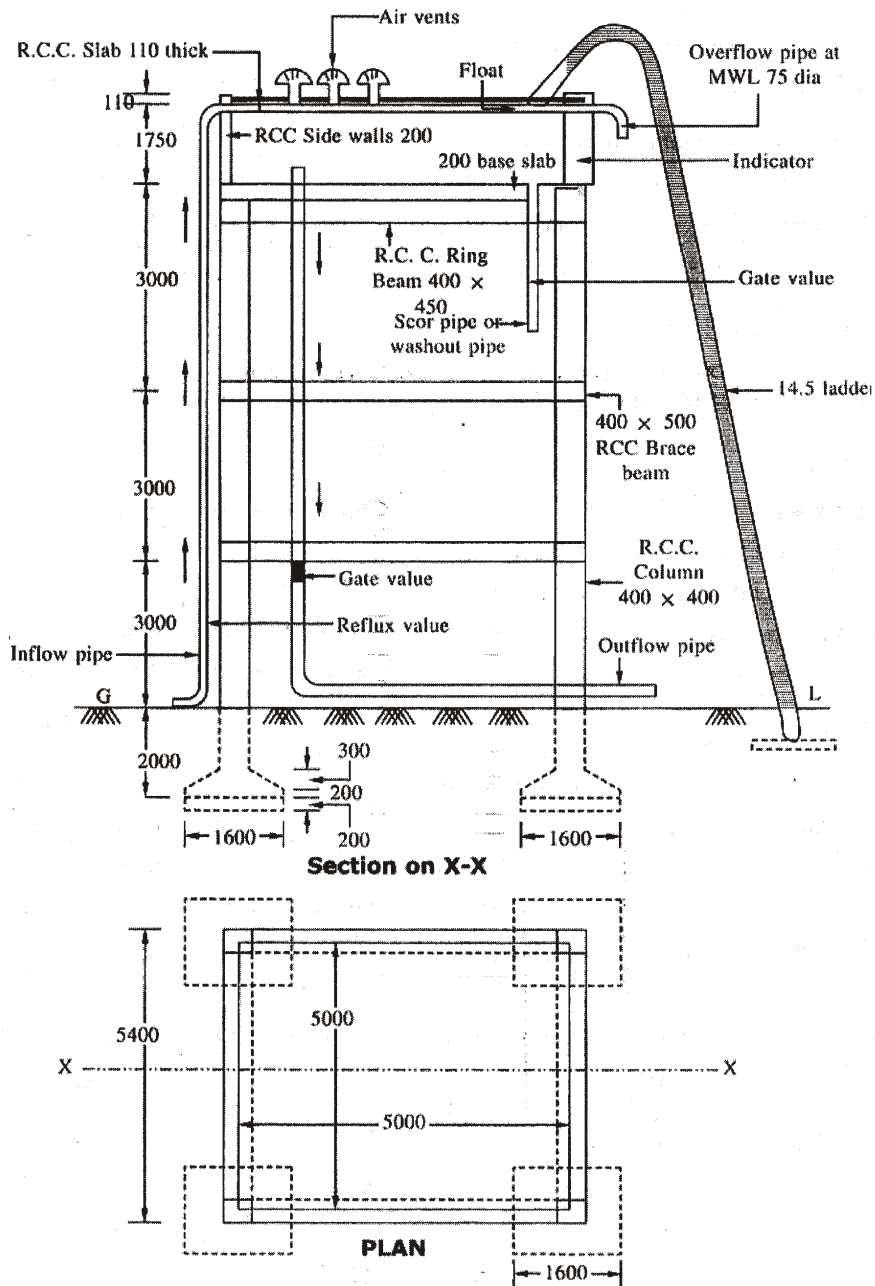

* 18. Calculate the quantities for the following items of work for an open well shown in the figure below :

(a) Earthwork excavation for open well

(b) Quantities of masonry in 3rd and 4th mattu's

