



c09-c-607

3728

BOARD DIPLOMA EXAMINATION, (C-09)

OCT/NOV—2017

DCE—SIXTH SEMESTER EXAMINATION

STRUCTURAL ENGINEERING DRAWING

Time : 3 hours]

[Total Marks : 60

PART—A

4×5=20

- Instructions :** (1) Answer **all** questions.
(2) Each question carries **four** marks.
(3) To be drawn not to scale.
(4) Assume suitable data, if necessary.

1. State any four guiding principles for positioning of columns in a structural planning of a building.
2. Redraw the figure given below and name the columns and beams as per the 'column reference scheme'.

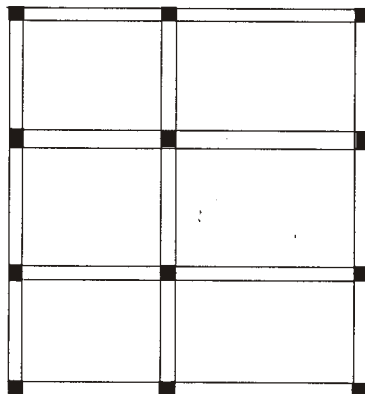

- * 3. Draw the longitudinal cross-section of an isolated square footing for a column with the following specifications :

Size of the column—400 mm × 400 mm

Size of the footing—2200 mm × 2200 mm

Thickness of the footing—450 mm (uniform)

Base coarse thickness—150 mm with PCC 1 : 4 : 8

Reinforcement for footing—12 mm dia at 150 mm c/c in both the directions

The horizontal lap length of the column reinforcing bar is 500 mm each

Reinforcement for column

Main bars—16 mm dia bars, 4 nos.

Lateral ties—8 mm dia ties at 200 mm c/c

All covers—50 mm

4. Prepare the bar bending schedule and find the quantity of steel required for the main reinforcement for the simply supported beam shown in the figure below. Top and bottom covers are 25 mm and side cover is 40 mm.

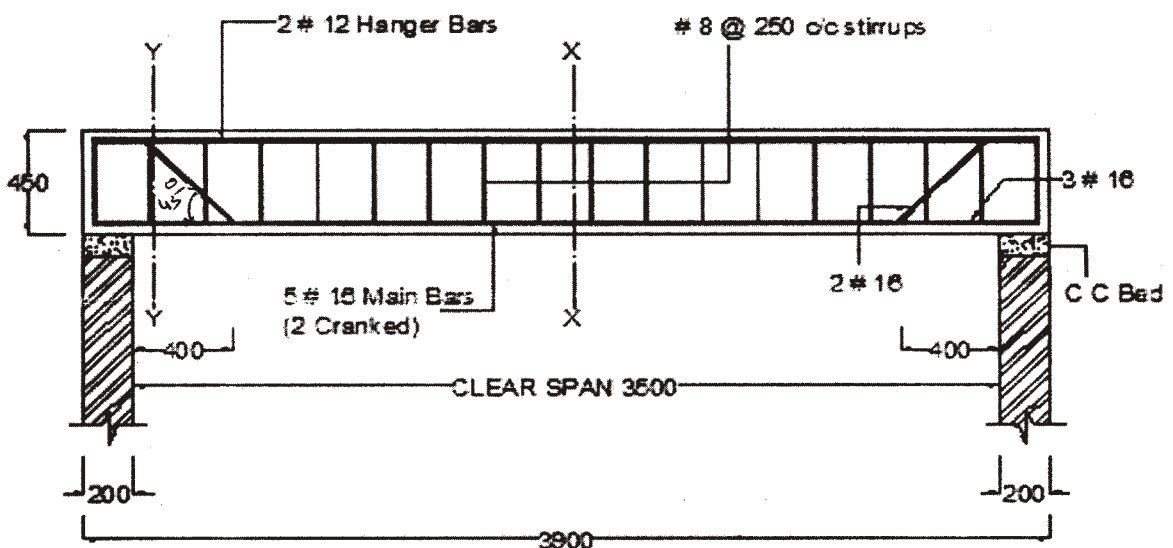

LONGITUDINAL SECTION

- * 5. Prepare the bar bending schedule and find the total quantity of steel required for the one-way slab shown in the figure below. Top and bottom covers are 20 mm and side cover is 25 mm.

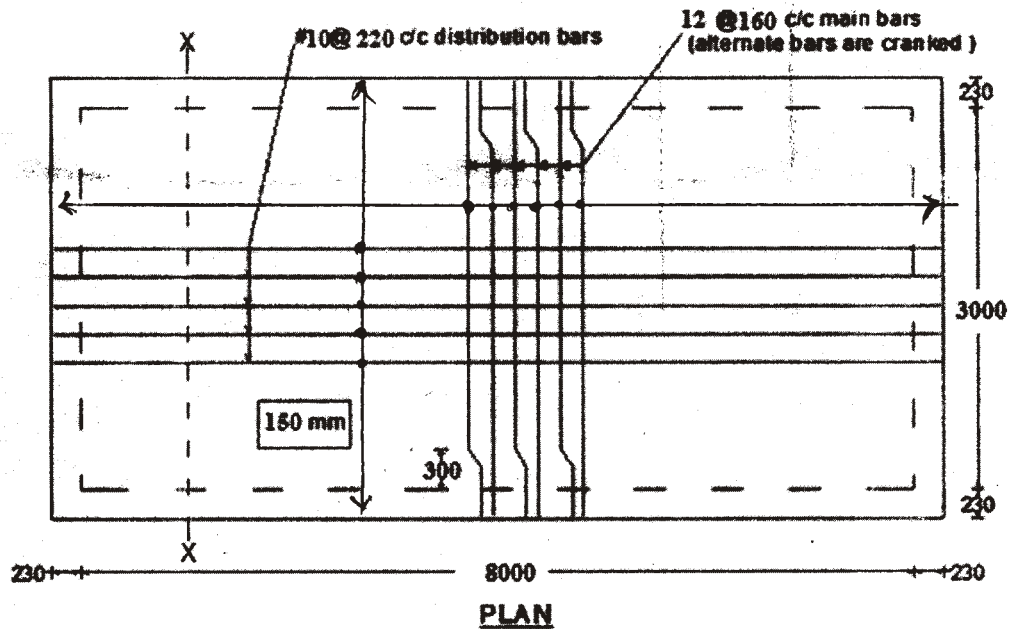

PART—B

20×2=40

- Instructions :** (1) Answer **all** questions.
 (2) Each question carries **twenty** marks.
 (3) Assume suitable data, if necessary.

6. Draw the reinforcement details of a lintel-cum-sunshade with the following specifications :

(i) Lintel

Clear span of the lintel—1800 mm

Size of the lintel—230 mm wide 250 mm depth

Bearing on either side—150 mm

Reinforcement

Main bars in tension—4#12, out of which 2 middle bars are cranked at a distance of 280 mm from the face of the support at 45°

*

Hanger bars—2#10

Stirrups—#6, two legged stirrups at 200 mm c/c
throughout

(ii) Sunshade

Projection of the sunshade—600 mm

Thickness at the fixed end—100 mm

Thickness at the free end—60 mm

Reinforcement

Main bars—#10, at 150 mm c/c

Distribution bars—#8, at 150 mm c/c

(iii) Covers

Bottom clear cover in lintel—25 mm

Top clear cover in sunshade—20 mm

All the remaining covers—25 mm

Draw the following views to a scale of 1 : 20

(a) Longitudinal section of lintel

(b) Cross-section at the mid span of lintel with sunshade

(c) Cross-section of lintel with sunshade near the support

10+5+5

7. Draw the reinforcement details of a simply supported RCC two-way slab whose corners are free to lift, with the following specifications :

(i) Specifications

Size of the room—4·0 m 5·0 m

Edge conditions—simply supported, corners not held
down

Overall depth of slab—140 mm

Bearing on walls—230 mm

(ii) Materials

Concrete—M-20 grade

Steel—Fe 415

*

(iii) Reinforcement

Along shorter span—#12 at 200 mm c/c (alternate bars are cranked at a distance of 400 mm from the face of the support)

Along longer span—#10 at 250 mm c/c (alternate bars are cranked at a distance of 500 mm from the face of the support)

Provide 3#8 hanger bars at each edge to keep top bars in position.

(iv) Covers

Top and bottom clear cover—20 mm

Side clear cover—25 mm

Draw the following views to a scale of 1 : 20 :

(a) Bottom plan of the reinforcement

(b) Top plan of the reinforcement

(c) Cross-section along the shorter span at mid span 10+5+5

*